

Address Resolution

ARP, RARP, Proxy ARP

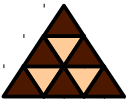

- **Address Resolution Protocol (ARP)**
 - ◆ IP Routing Basics
 - ◆ IP Forwarding and ARP
- **RARP**
- **Proxy ARP**
- **ICMP**
 - ◆ IP Forwarding and ICMP



Address Resolution Protocol

Why ARP?



- **On a multipoint network every station needs a layer-2 address**
- **When IP packets should be sent to a local destination the sender must first determine the corresponding layer-2 address**
- **The layer-2 address could be a MAC address, a DLCI (Frame-Relay) or similar**
 - ◆ **In this chapter we only focus on Ethernet**

ARP Format

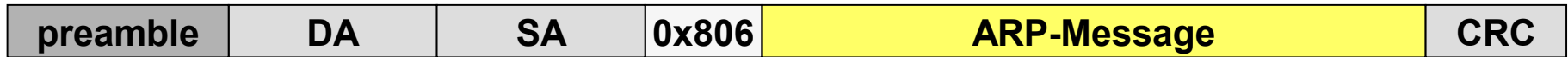

Ethernet II Frame

0 8 16 24 32

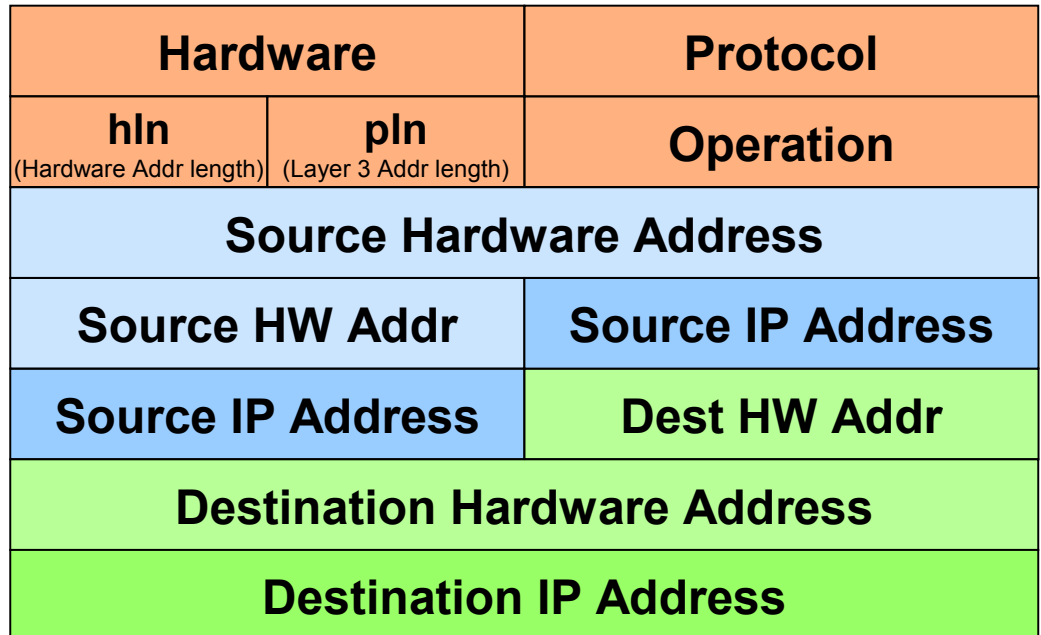

Example ARP Request (Ethernet / IP):

Hardware: 6 (IEEE802.x)

Protocol: 0x0800 (IP)

hln: 6 (MAC Address in Bytes)

pln: 4 (IP Address in Bytes)

Operation: 1 (ARP Request)

Source HW Addr: hex: 00 60 97 bc 88 f1

Source IP Addr: 192.168.1.1

Dest HW Addr: hex: ff ff ff ff ff ff

Dest IP Addr: 192.168.1.254

Routing Differences



- Routing = finding a path to a destination address
- **Direct delivery** performed by host
 - ◆ Destination network = local network
- **Indirect delivery** performed by router
 - ◆ Destination network \neq local network
 - ◆ Packet is forwarded to **default gateway**



- **IP host checks if packet's destination network is identical with local network**
 - ◆ **By applying the configured subnet mask of the host's interface**
- **If destination network = local network then the L2 address of the destination is discovered using ARP**
 - ◆ **Remember: not necessary for point-to-point connections**

Direct Delivery



- Sent as Broadcast

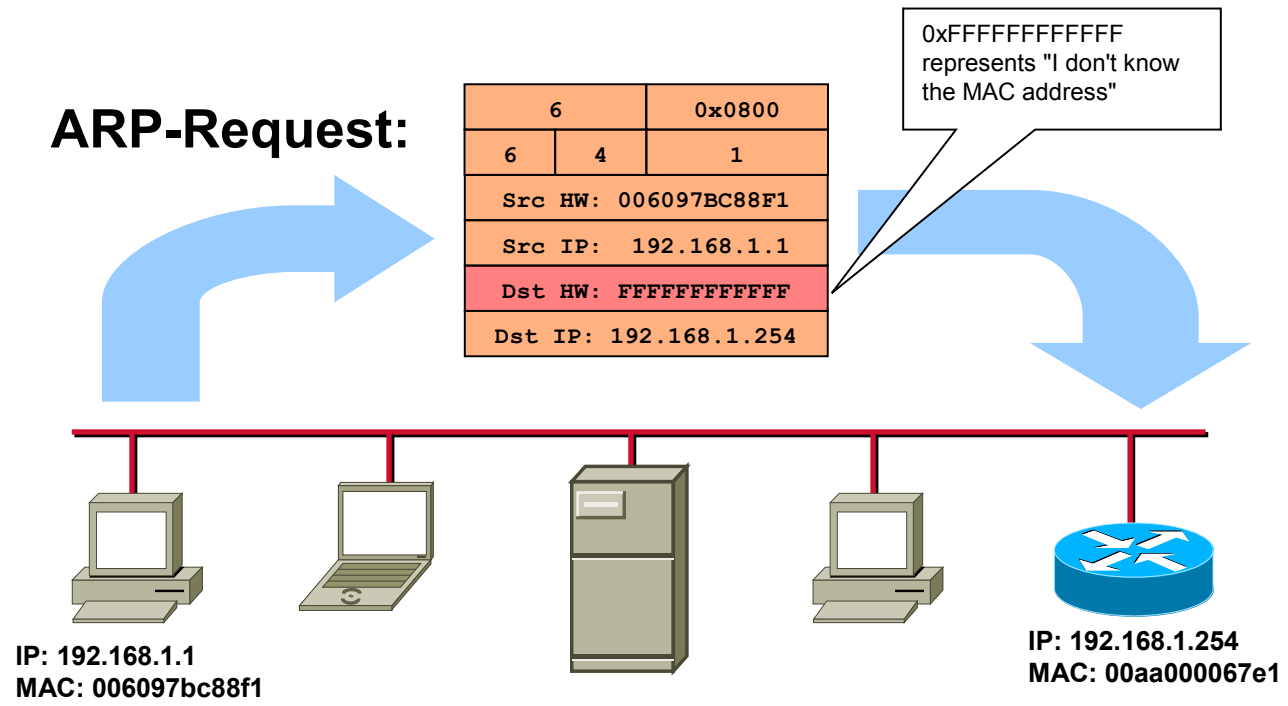

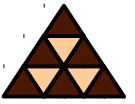

Direct Delivery

- Response is unicast

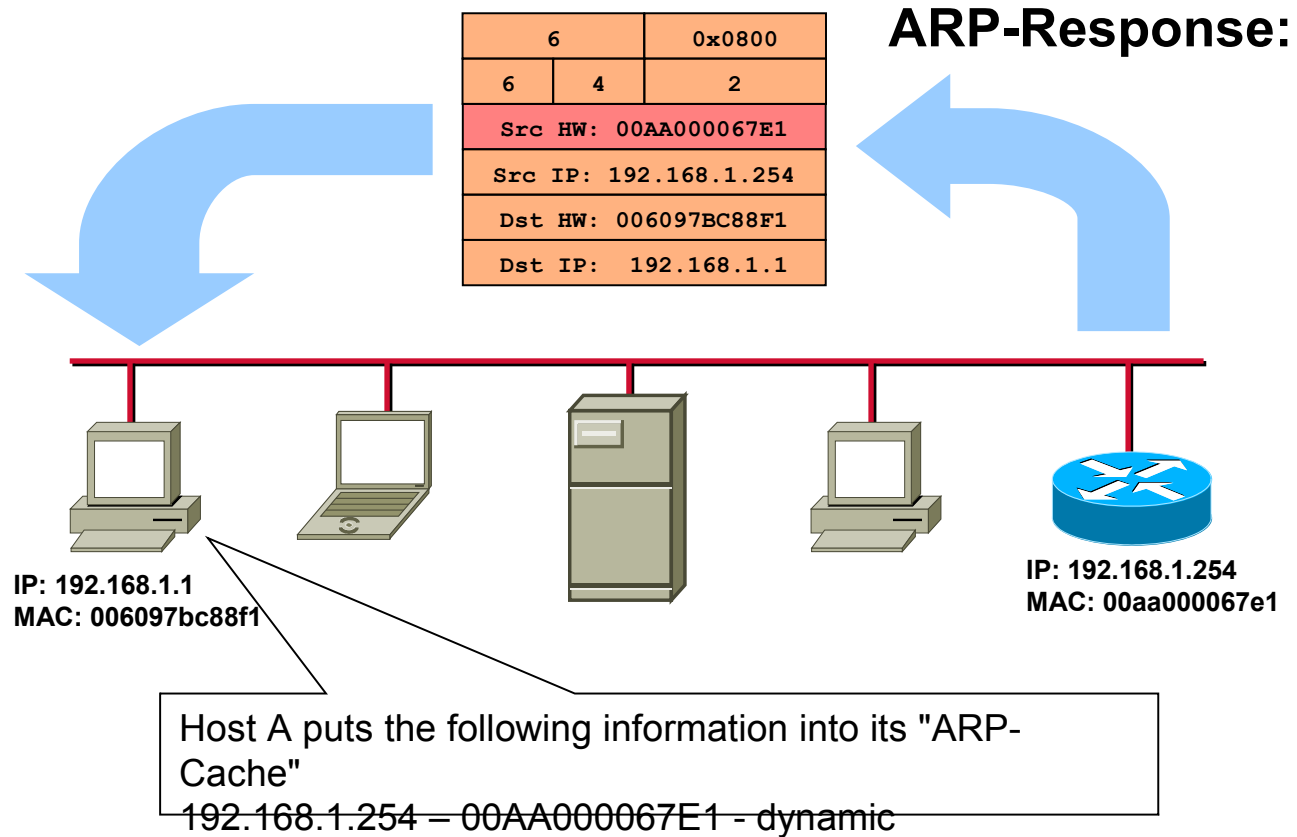



- Learned MAC addresses are stored in an **ARP-cache**
 - ◆ Aging timer: **20 minutes**
- IP hosts have also routing tables !
 - ◆ But typically only a static route to the default gateway is entered
 - ◆ Default gateway for indirect delivery

Using the Default Gateway



- **Default gateway delivers packet in behalf of its host using a routing table**
- **Host must determine MAC address of default gateway using ARP**
- **IP datagram is handed over to default gateway**

Indirect Delivery (1)

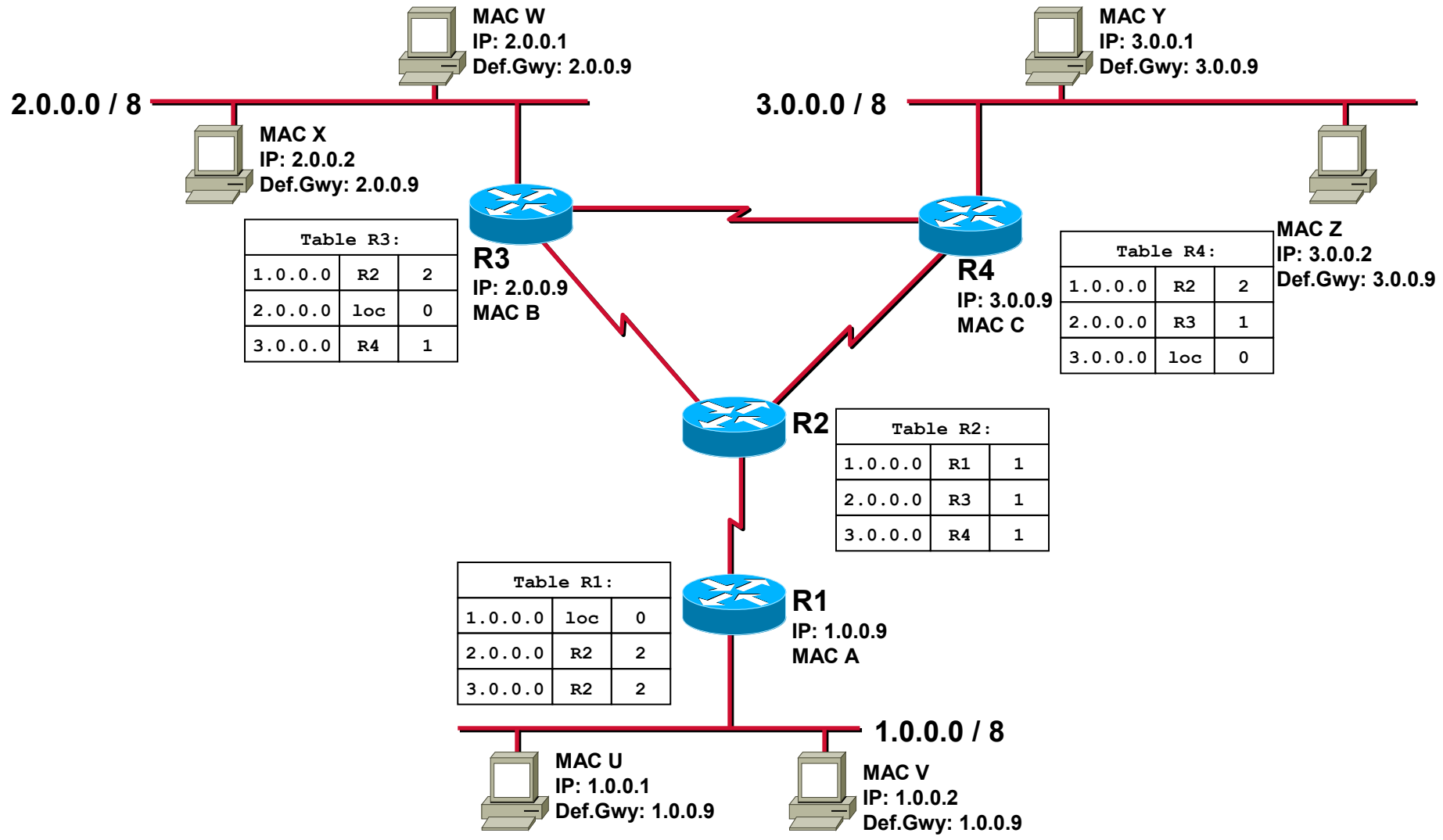

Indirect Delivery (2)

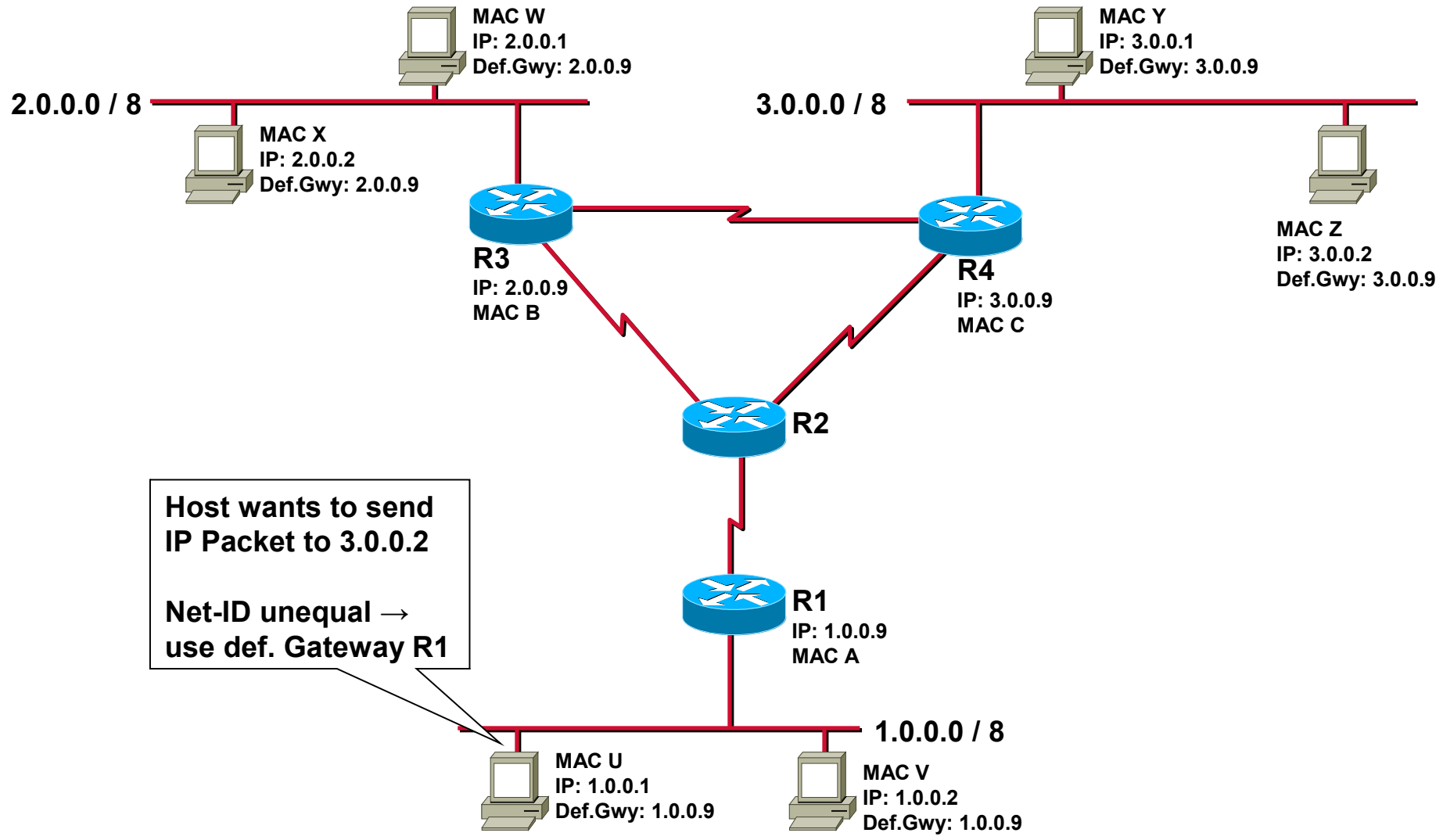

Indirect Delivery (3)

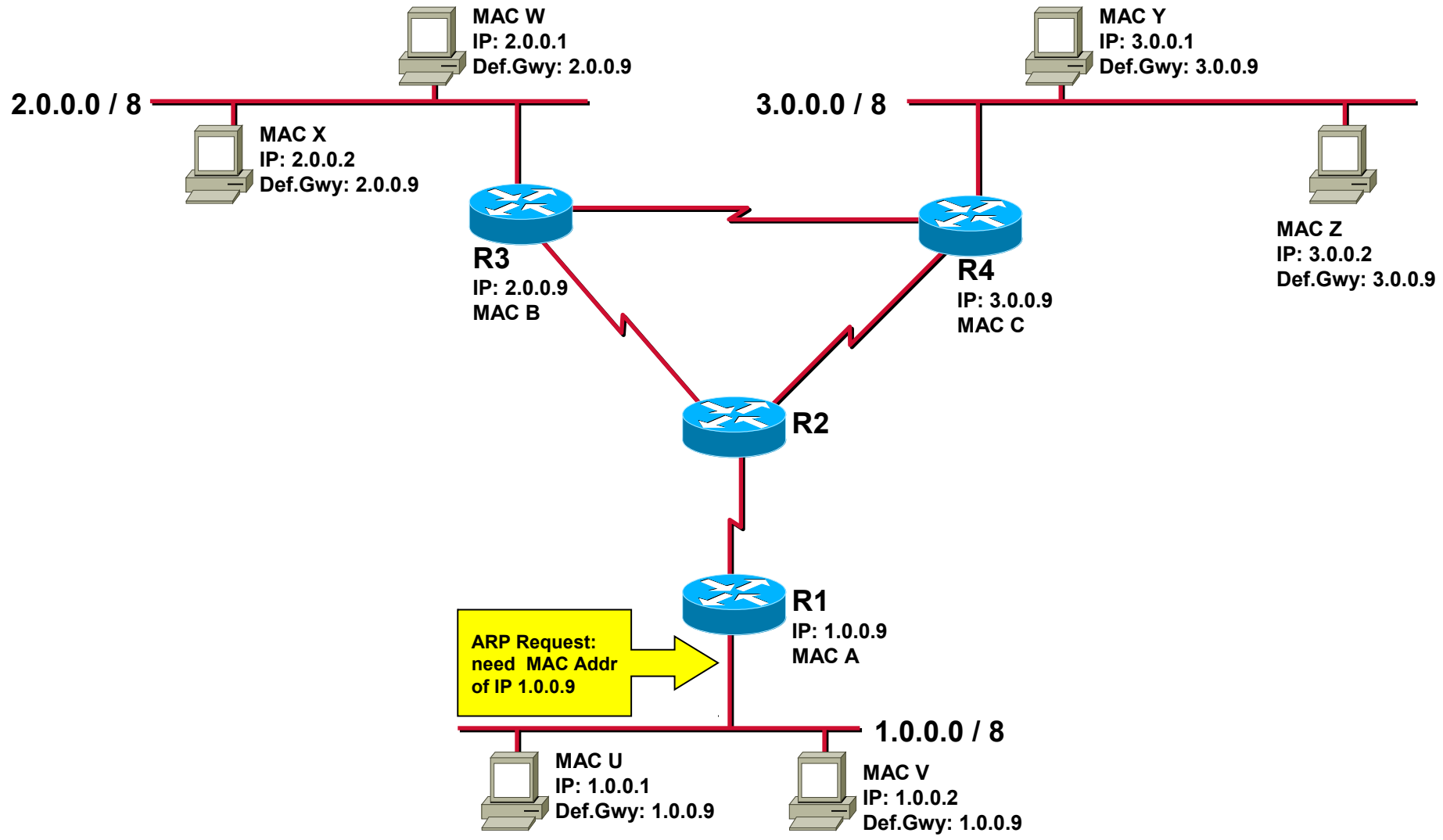

Indirect Delivery (4)

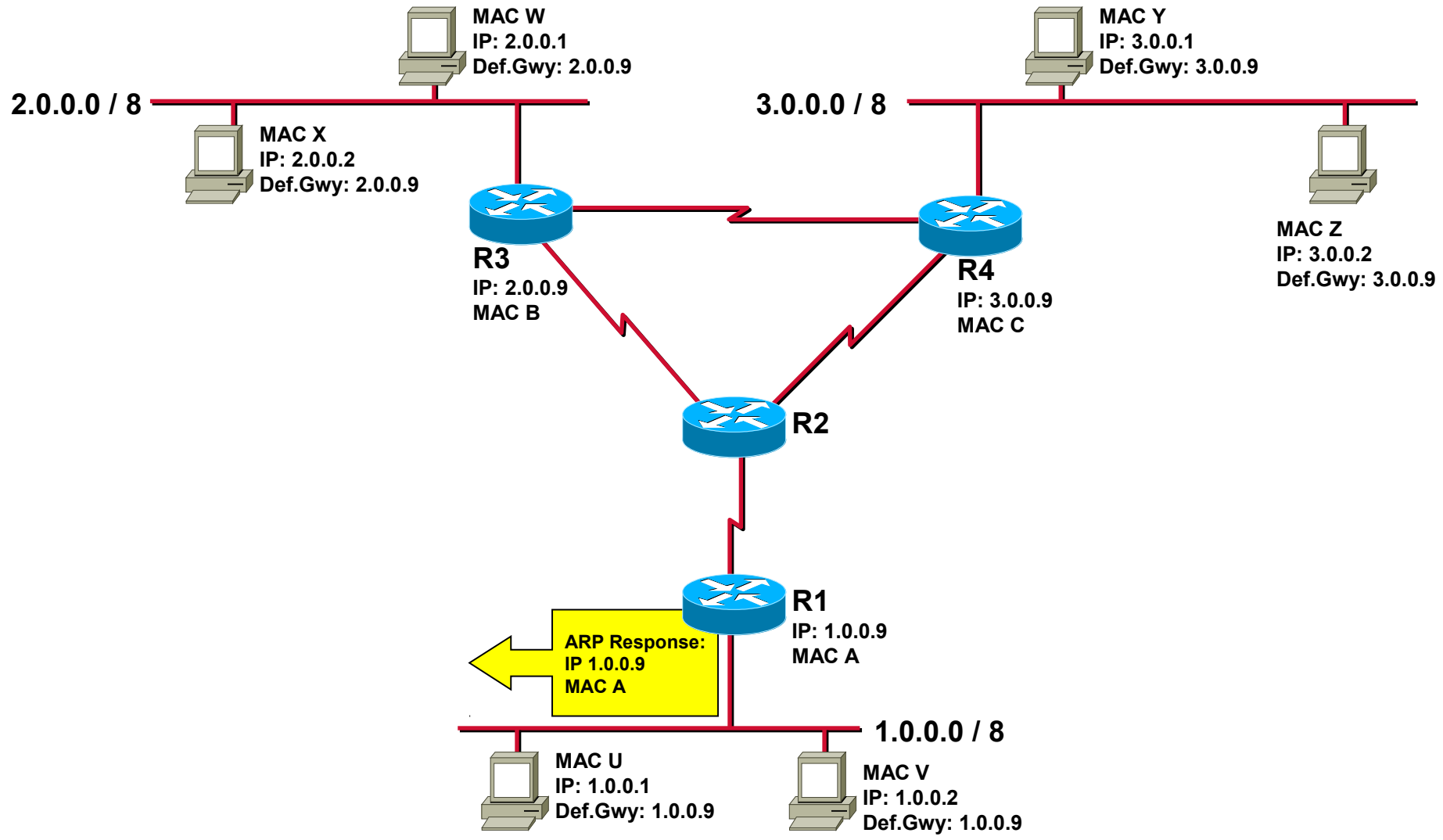

Indirect Delivery (5)

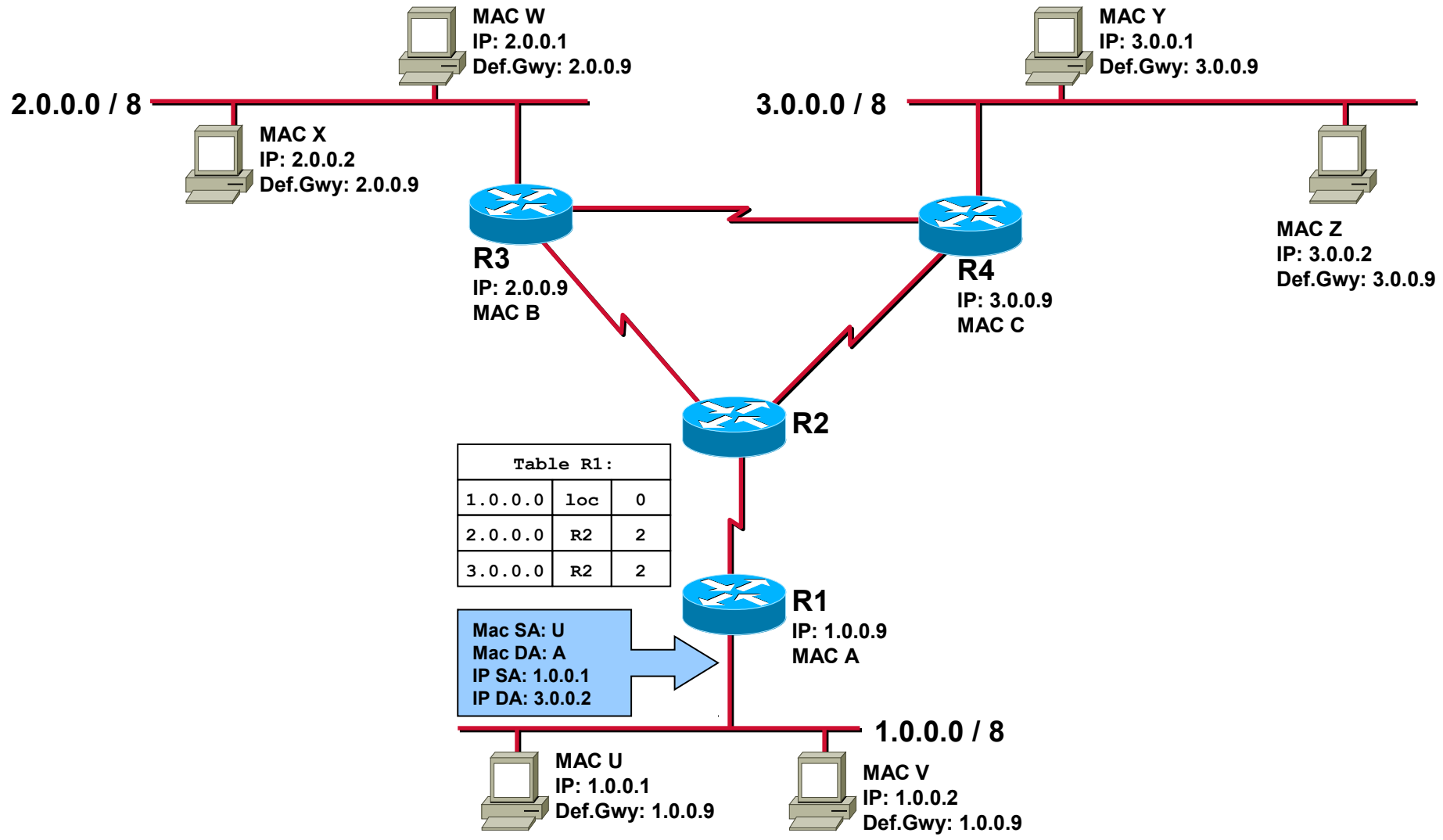

Indirect Delivery (6)

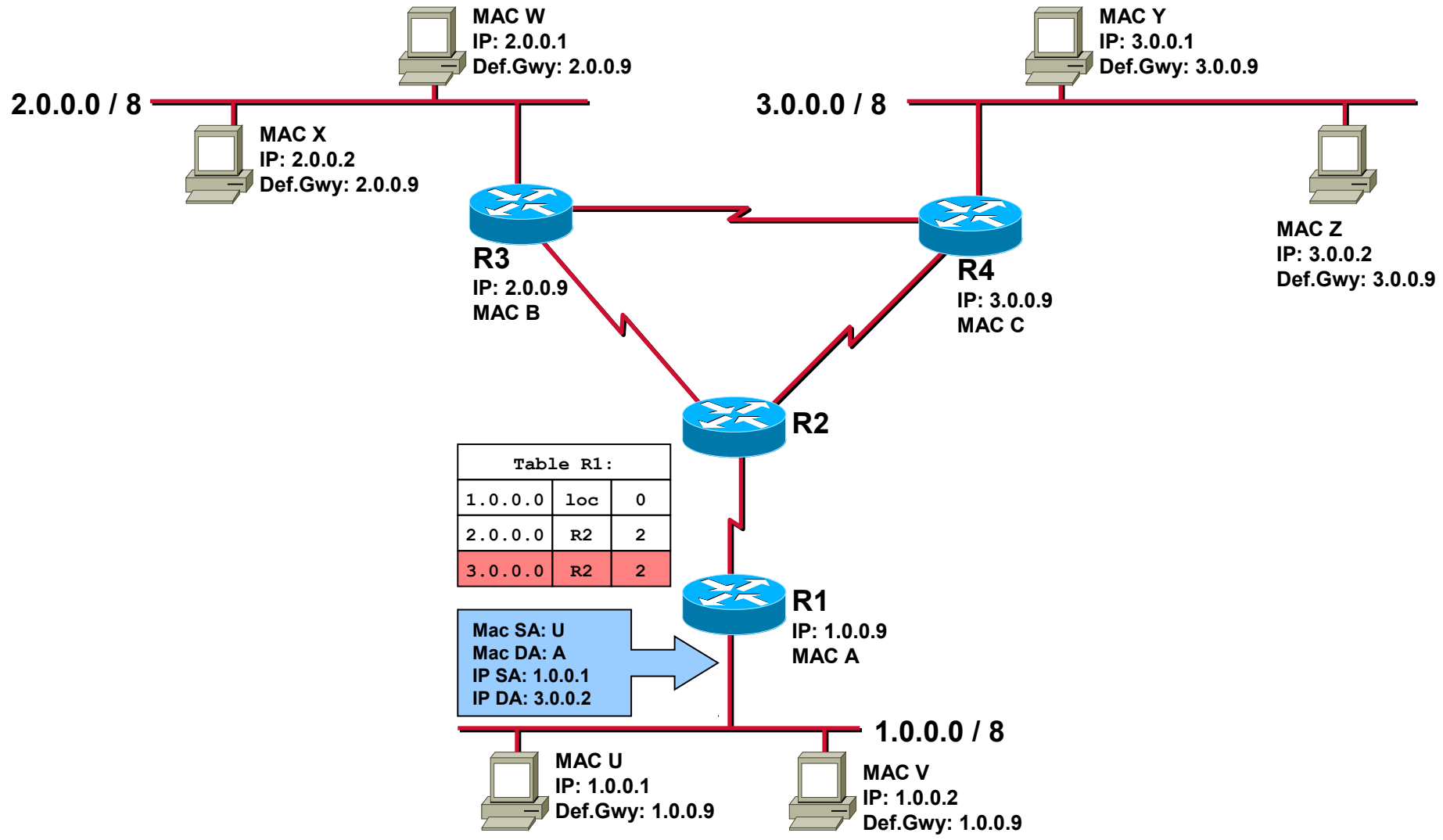

Indirect Delivery (7)

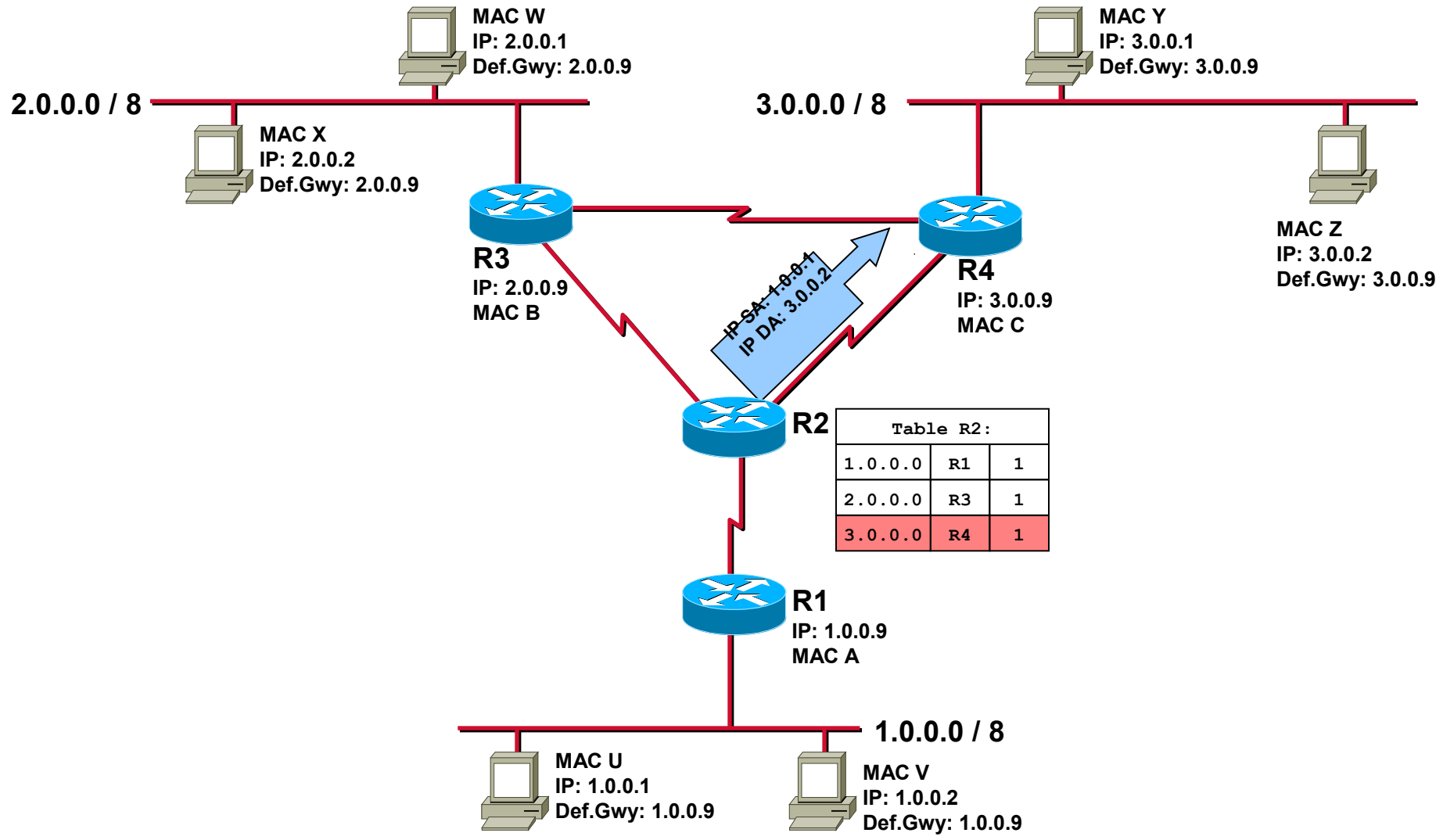

Indirect Delivery (8)

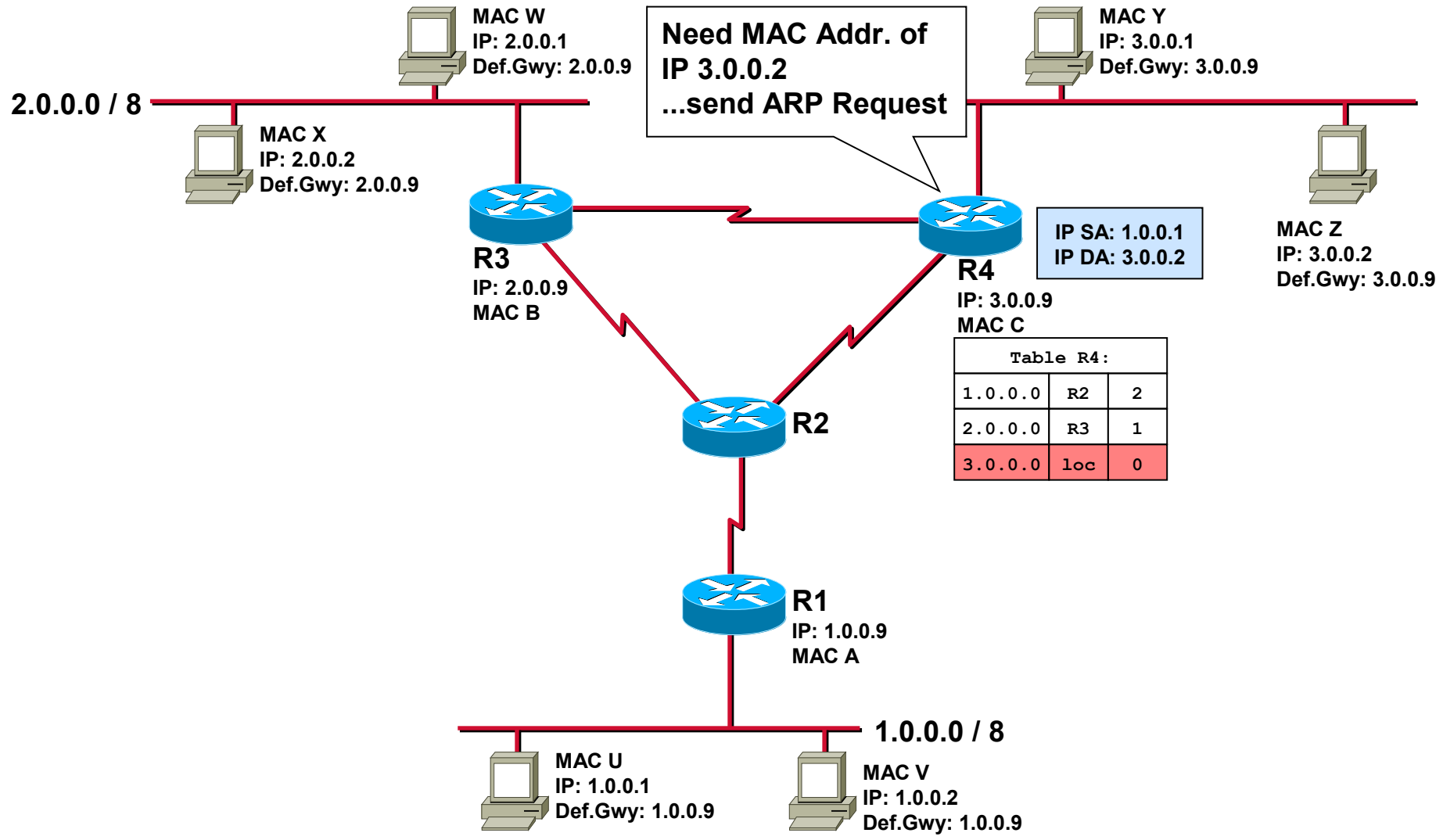

Indirect Delivery (9)

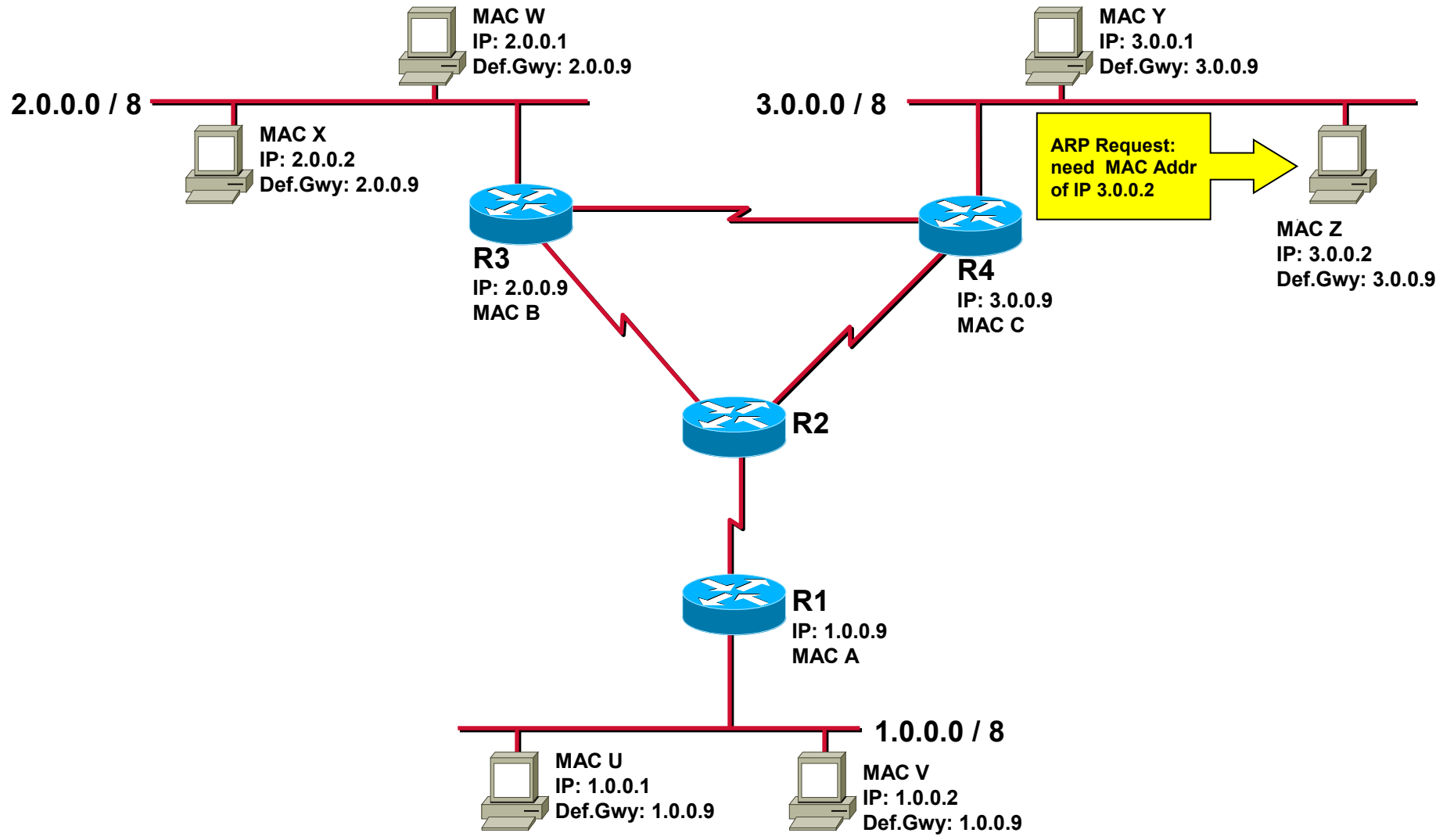

Indirect Delivery (10)

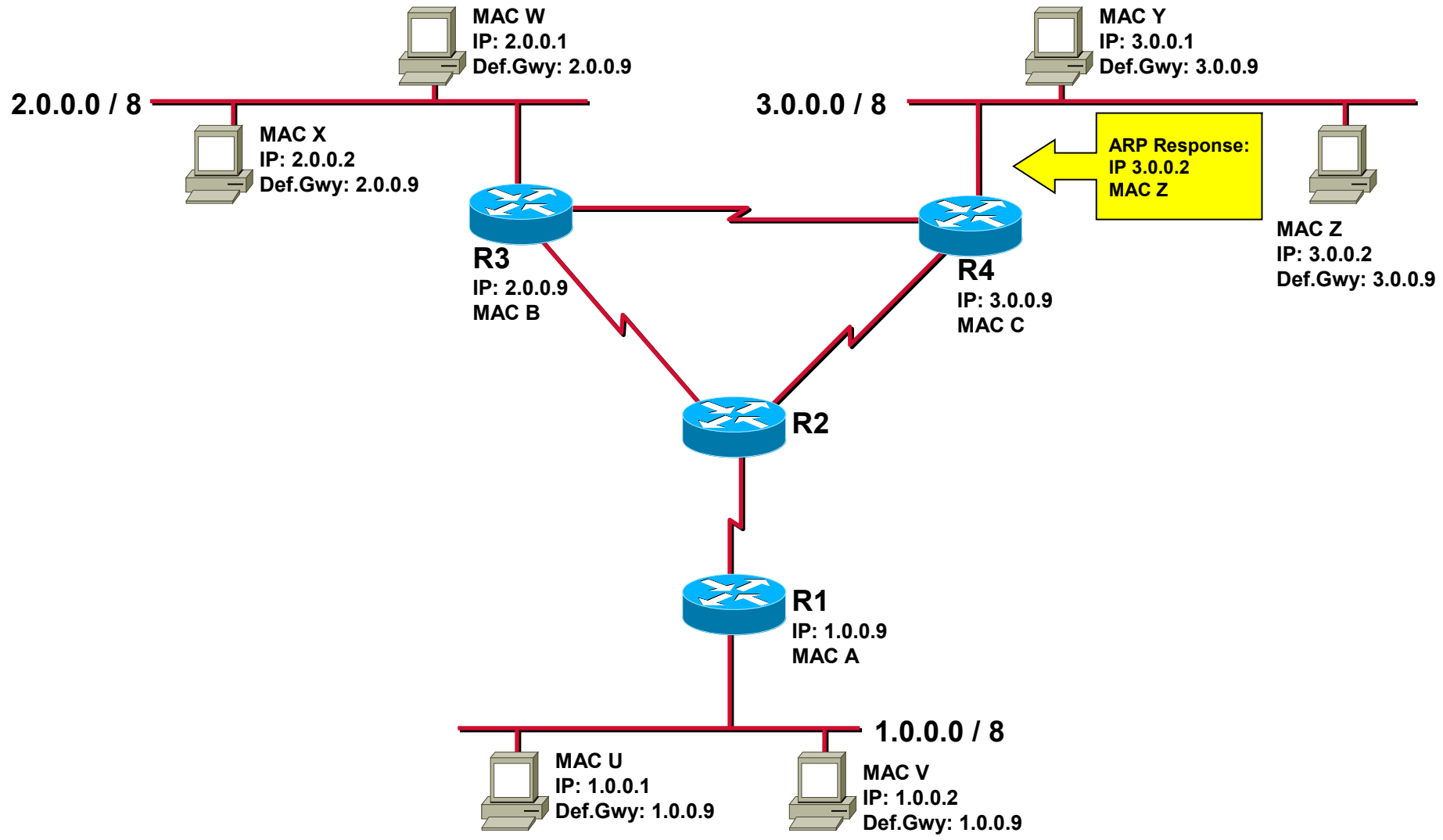

Indirect Delivery (END)

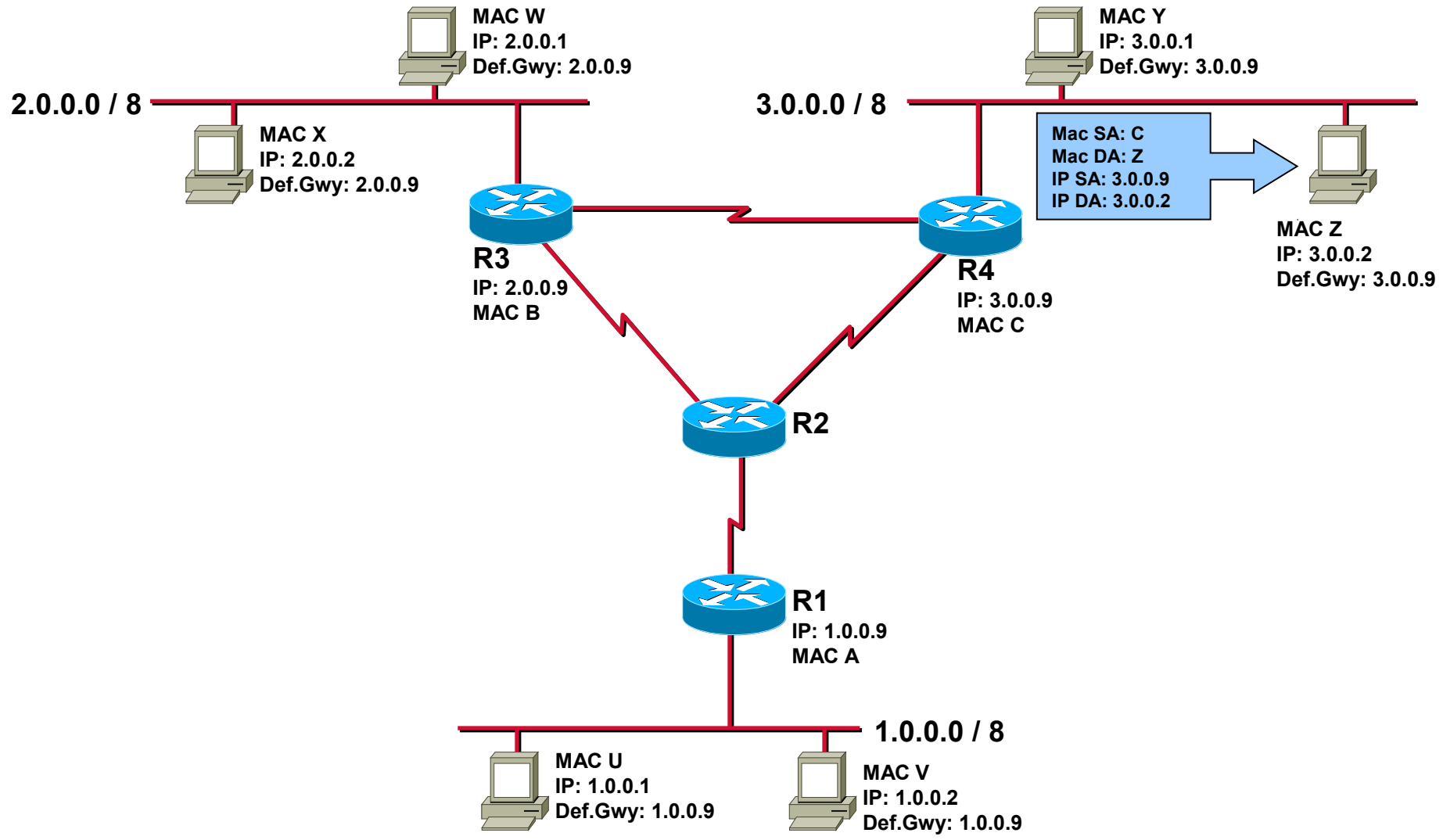



Reverse ARP

Reverse ARP (RARP)



- **ARP assumes, that an IP station knows its IP address (stored in NVRAM, on hard disk, in config file etc.).**
- **Diskless Machines usually don't have such means so they must retrieve an IP address for network booting.**
- **RARP (Reverse ARP) provides IP addresses for unconfigured stations.**
- **RFC 903**

Reverse ARP (RARP)



- A station sends a RARP request broadcast.
- One station, the RARP server, looks up the IP address for that MAC address in a database and replies.
- Newer methods:
 - ◆ BOOTP
 - ◆ DHCP

Reverse ARP (RARP)

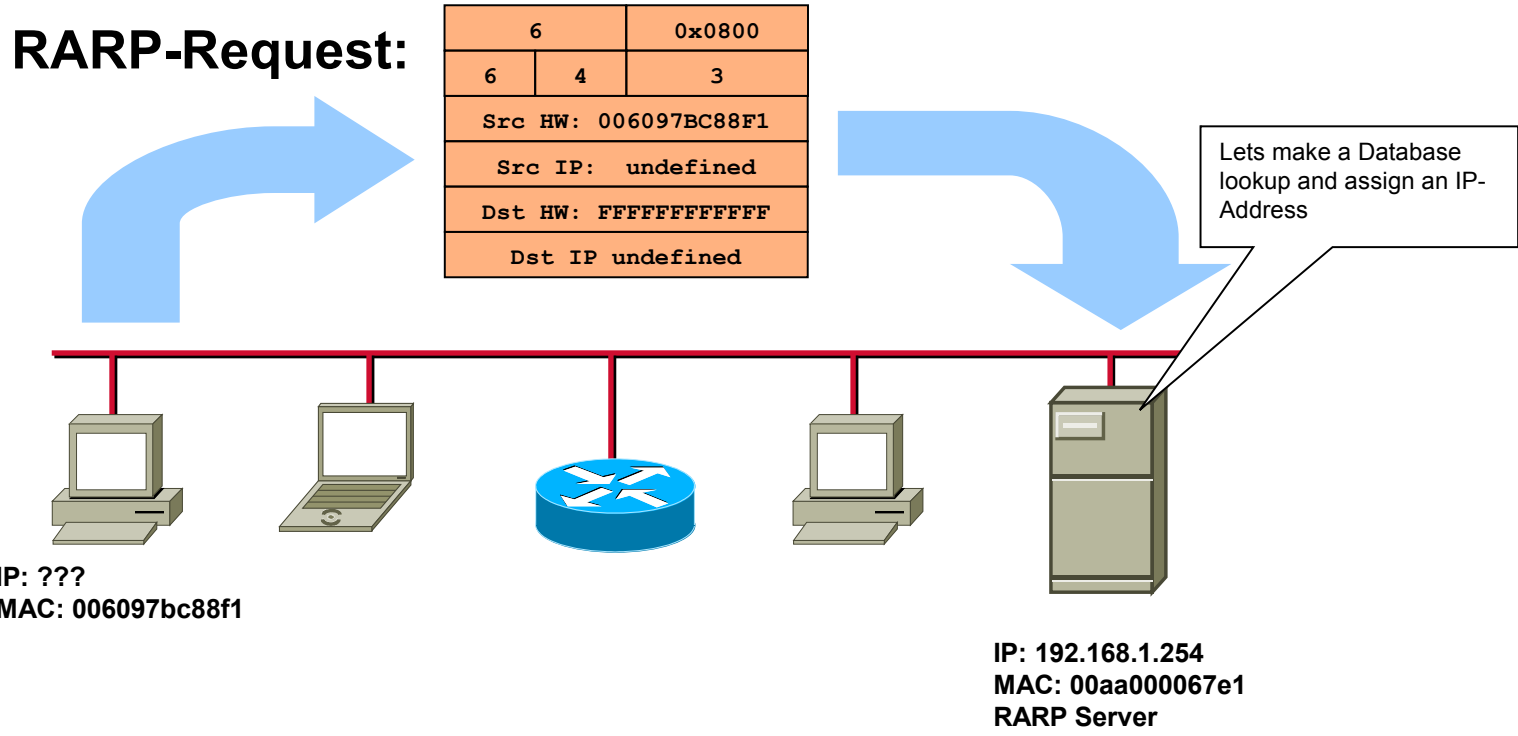

Reverse ARP (RARP)

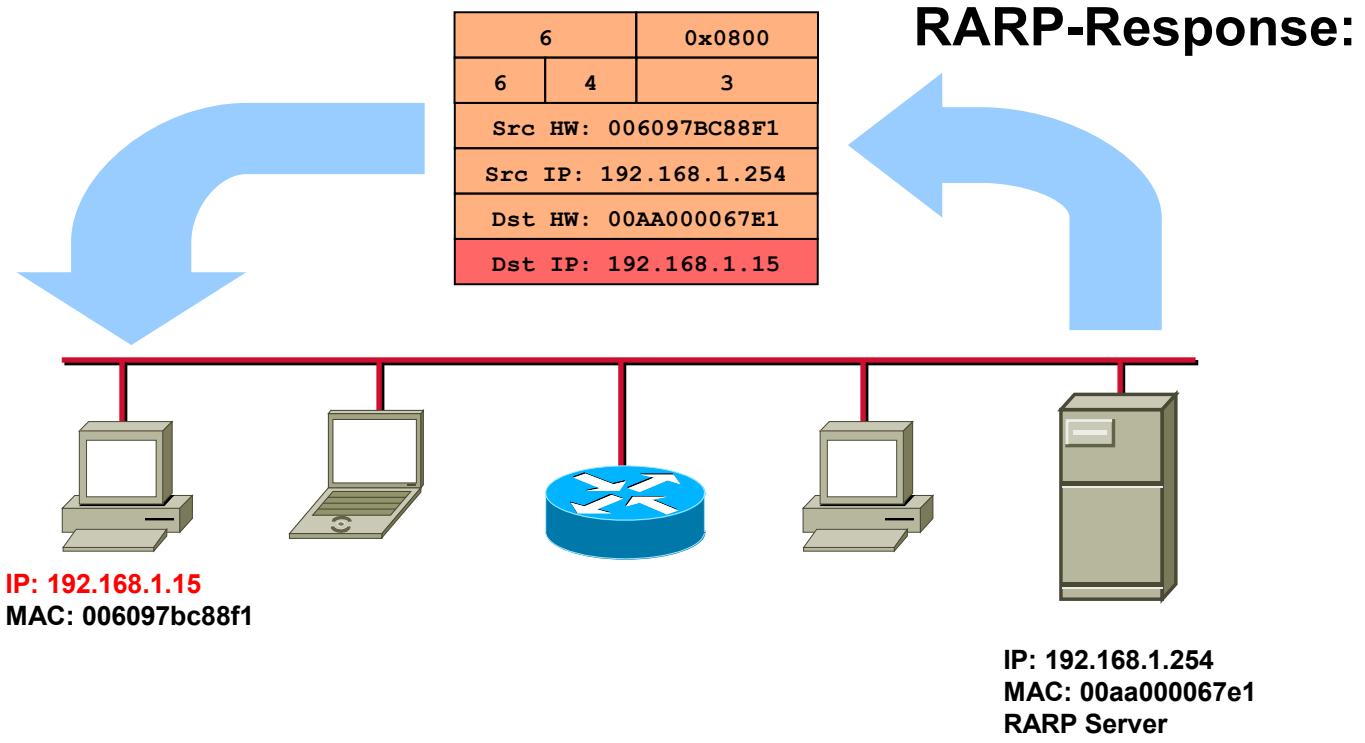



Proxy ARP

"The ARP Hack"

Proxy ARP (1)



- Router connect only networks with different net-IDs
- Router with Proxy ARP enabled also connect networks with **same Net-ID**
 - ◆ Router replies on ARP request in behalf of station in other segment
 - ◆ Security or performance reasons
- “proxy” simply means *“instead of”*

Proxy ARP (2)



- **Using Proxy ARP on routers, hosts do not need default gateway or routing entries to reach other subnets**
- **Default router's address = own interface address**
 - ◆ **Force ARP for every destination address**
- **If the local router is configured for Proxy-ARP it replies with an ARP response claiming to be the destination host**
 - ◆ **Then accepts and forward the IP packet**
 - ◆ **Cisco routers have Proxy-ARP enabled by default**

Proxy ARP (3)



Proxy ARP Request

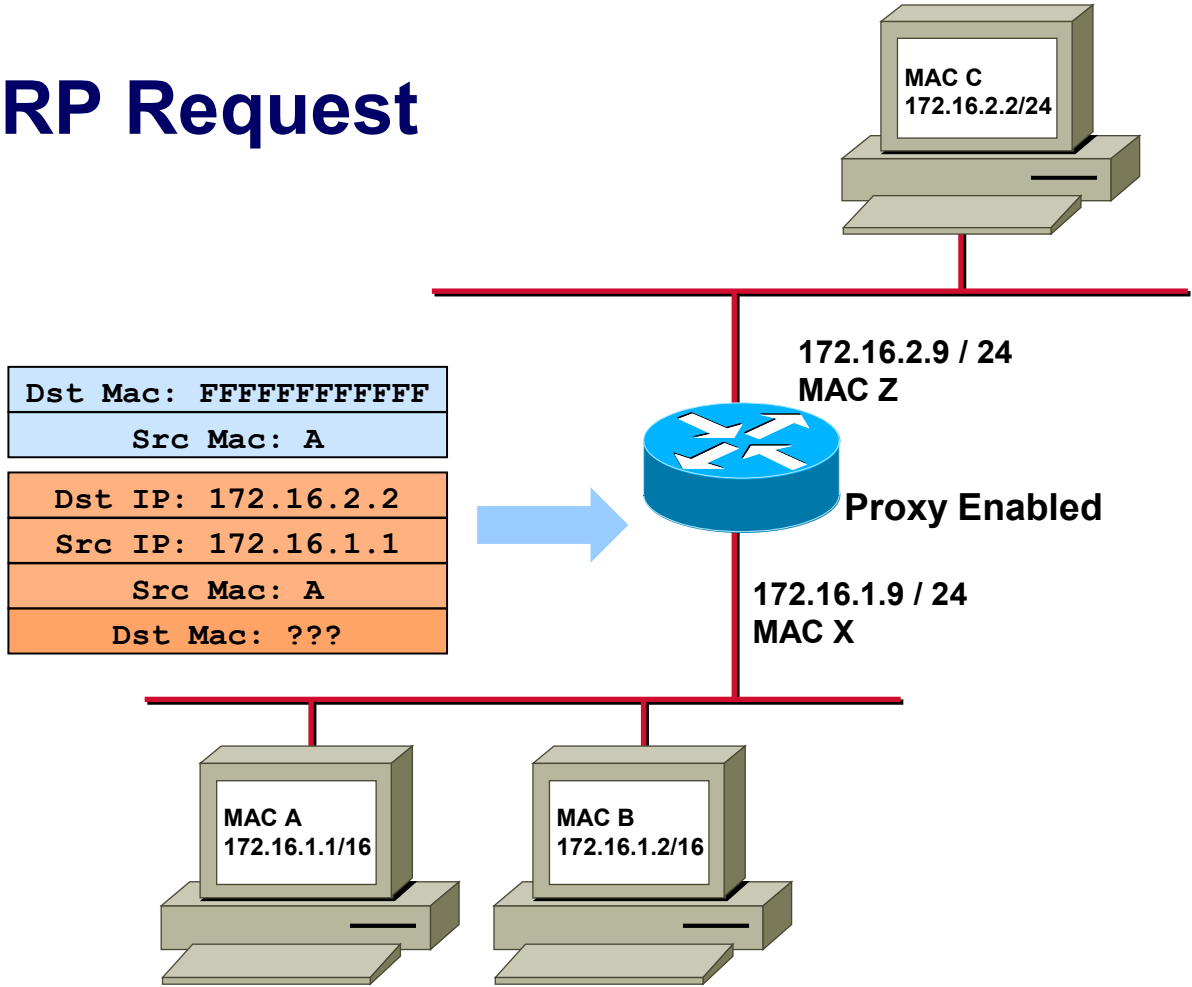

Proxy ARP (4)



Proxy ARP Response

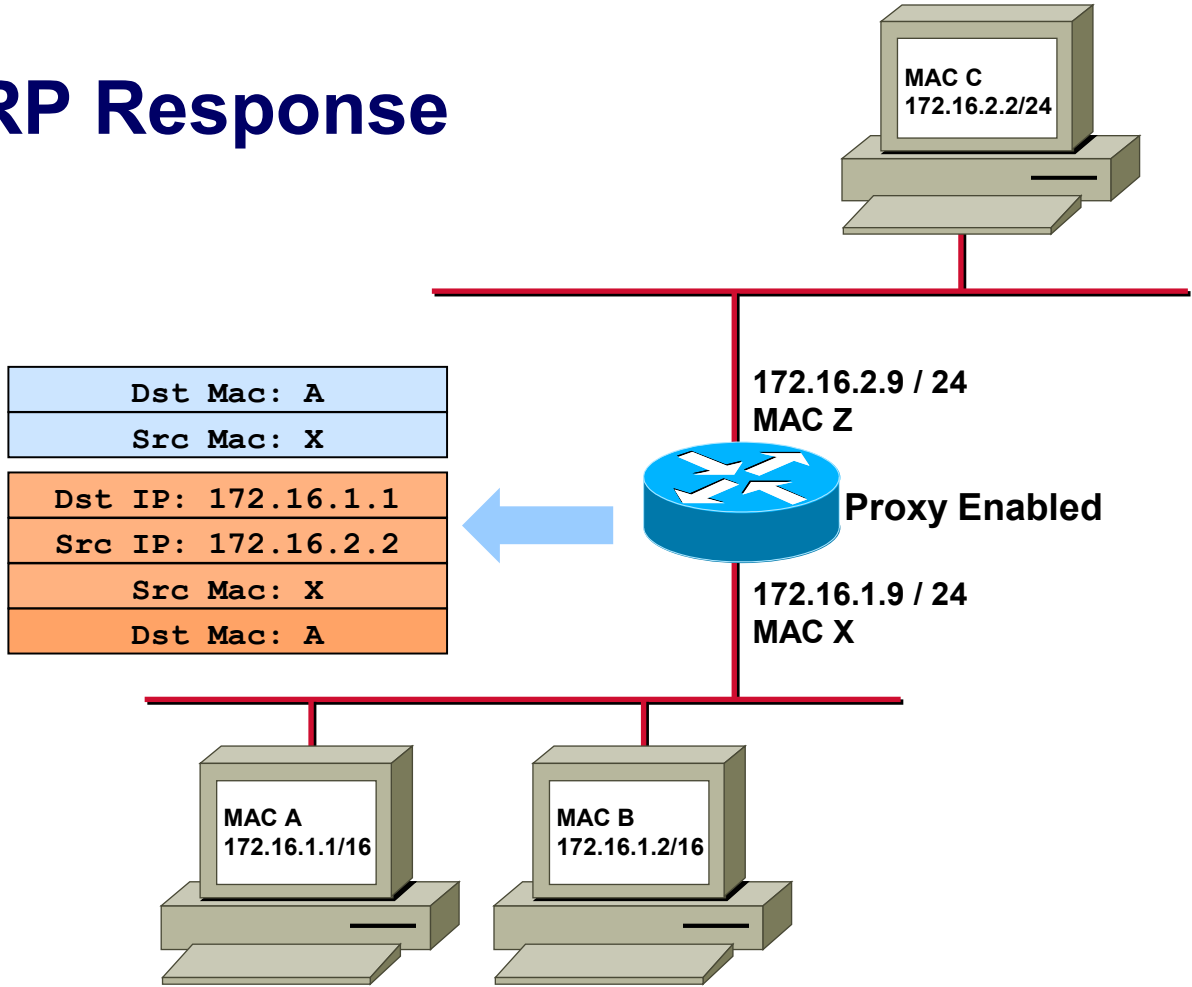

Rules (1)



- **Proxy ARP only allowed to hide **subnets** – *not networks* !**
 - ◆ **Proxy ARP GW should not be used to bypass normal GWs**
- **Multiple Proxy ARP GWs**
 - ◆ **Requesting host will use the first ARP response it receives**
 - ◆ **Simple load balancing service**

Rules (2)



- **Proxy ARP GWs must not reply if the destination is reachable through the same interface**
 - ◆ **Either destination is in same segment**
 - ◆ **Or another Proxy ARP GW will reply, knowing a better route**

Disadvantages



- **Much ARP traffic**
 - ◆ Forwarded by bridges! (Broadcasts)
- **Hosts need larger ARP caches**
- **Address spoofing possible**
 - ◆ Station claims to be another station



ICMP



- **If network cannot deliver packets the sender must be informed somehow !**
 - ◆ **Reasons: no route, TTL expired, ...**
- **ICMP enhances network reliability and performance by carrying error and diagnostic messages**
- **ICMP must be supported by every IP station**
 - ◆ **Implementation differences!**



- Any station (host or router) detecting transmission problems sends ICMP error message back to the originator
- **ICMP gives feedback**
- ICMP messages are carried within IP packets
 - ◆ Protocol field = 1
 - ◆ ICMP header and code in the IP data area



- If a IP packet carrying an ICMP message cannot be delivered
 - ◆ No additional ICMP error message is generated to avoid an ICMP avalanche
 - ◆ **"ICMP must not invoke ICMP"**
- Exception: PING command
 - ◆ Echo request and echo response
 - ◆ Microsoft's tracert expects "TTL expired" upon "Echo request"

ICMP Message Format

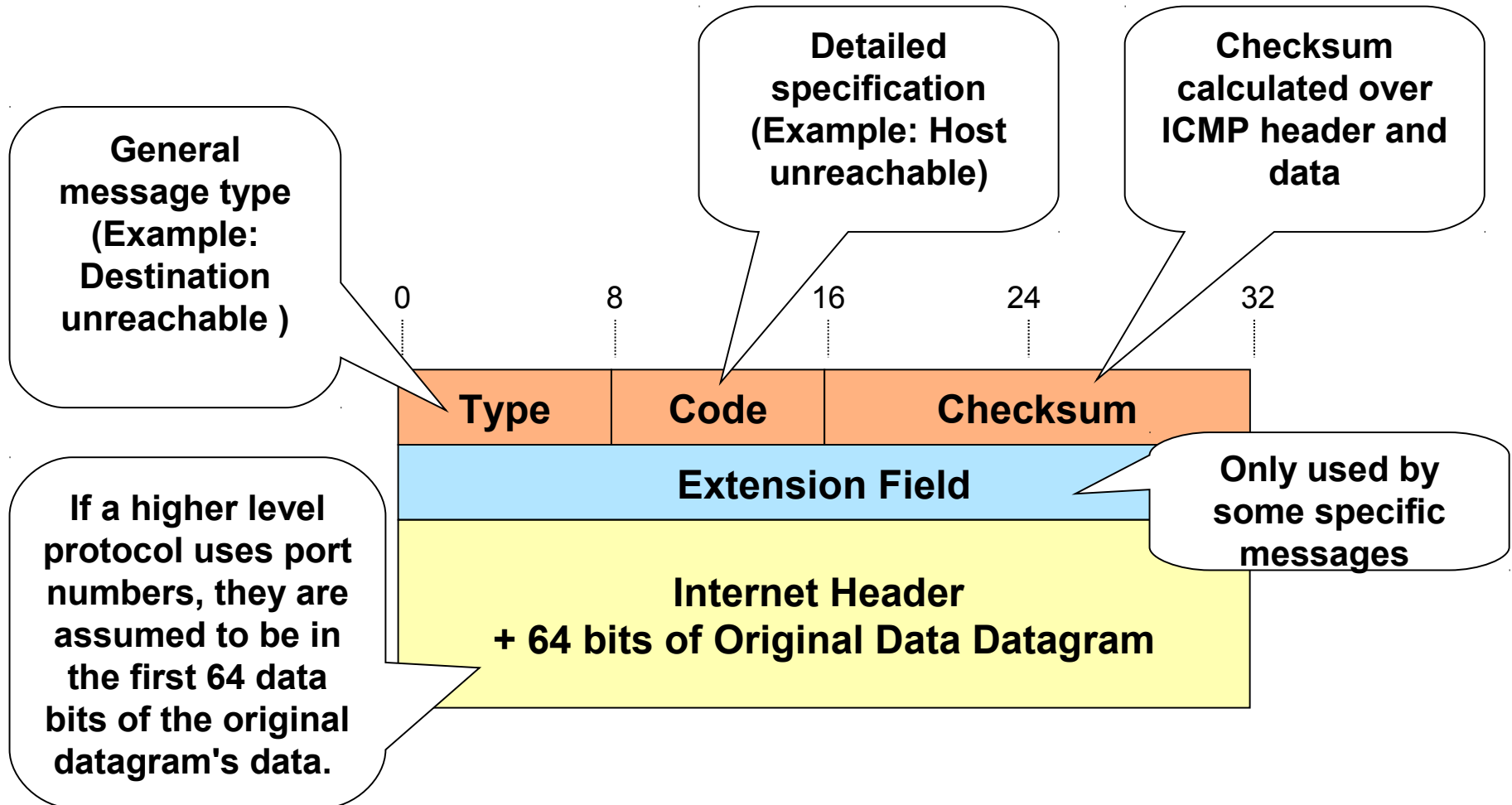

Type Field Values



- (0)** - Echo reply ("PING")
- (3)** - Destination Unreachable
- (4)** - Source Quench (decrease data rate of sender)
- (5)** - Redirect (use different router)
- (8)** - Echo Request ("PING")
- (11)** - Time Exceeded (TTL = 0 or reassembly timer expired)
- (12)** - Parameter Problem (IP header)
- (13)** - Time Stamp Request
- (14)** - Time Stamp Reply
- (15/16)** - Information Request/Reply (finding the Net-ID of the network; e.g. SLIP)
- (17/18)** - Address Mask Request/Reply

Example: Codes for Type 3



- (0) - Network unreachable: no path to network known or network down; generated by intermediate or far-end router.**
- (1) - Host unreachable: Host-ID can't be resolved or host not responding; generated by far-end router.**
- (2) - Protocol unreachable: protocol specified in IP header not available; generated by end system.**
- (3) - Port unreachable: port (service) specified in layer 4 not available; generated by end system.**
- (4) - Fragmentation needed and do not fragment bit set: DF bit =1 but the packet is too big for the network (MTU); generated by router.**
- (5) - Source route failed: Path in IP Options couldn't be followed; generated by intermediate or far-end router.**

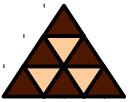

IP Forwarding und ICMP(1)

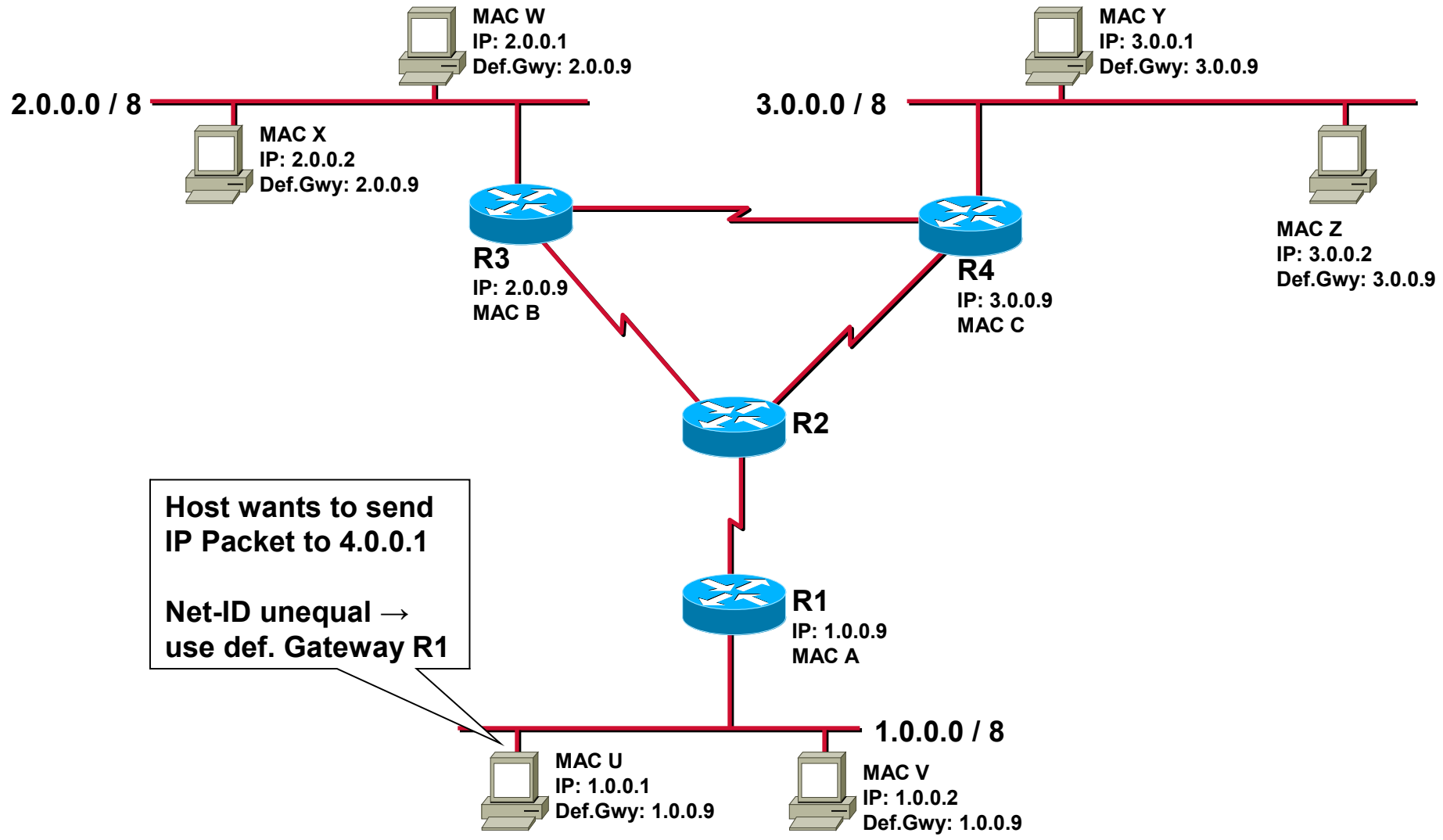

IP Forwarding und ICMP(1)

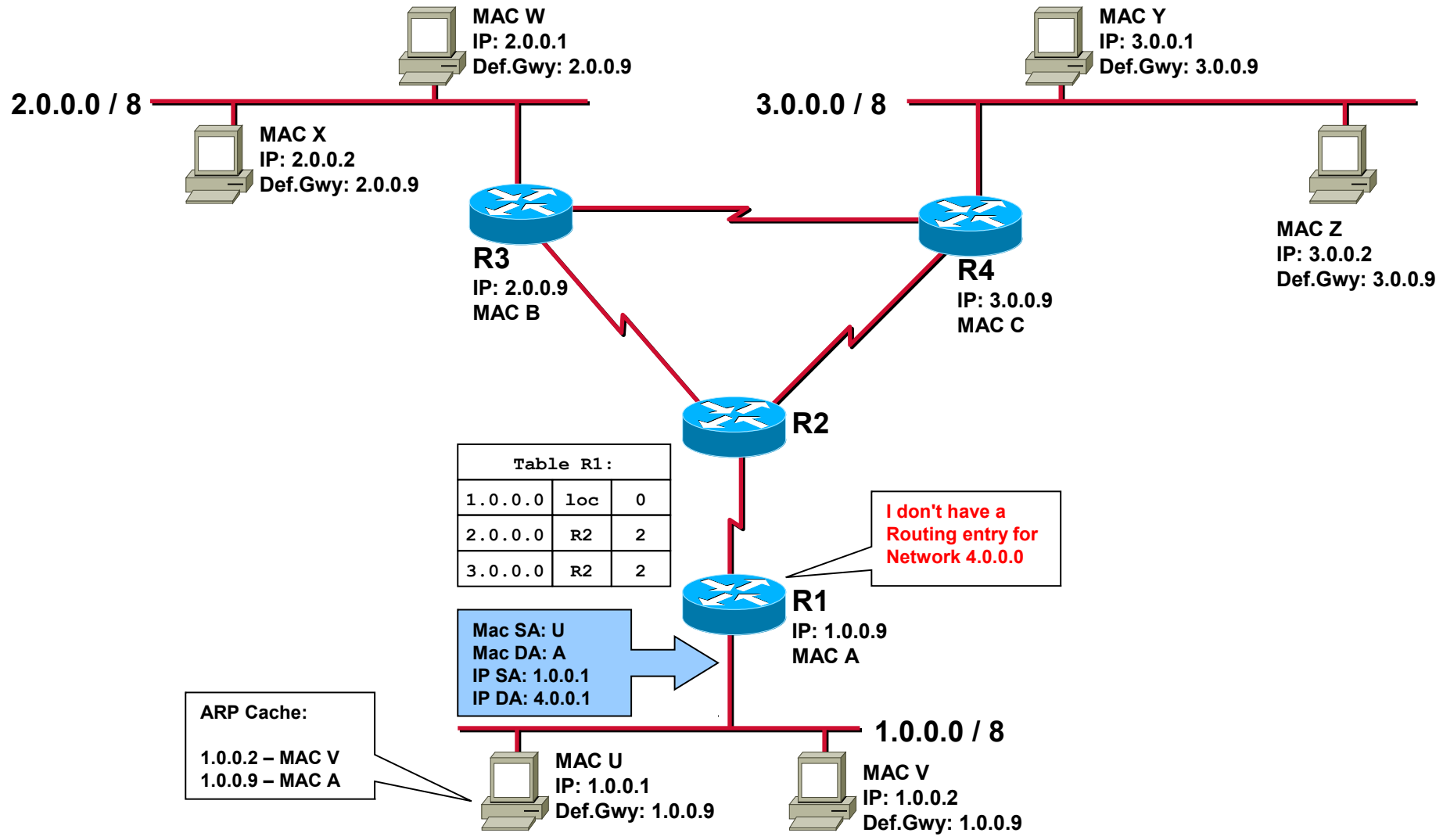

IP Forwarding und ICMP(1)

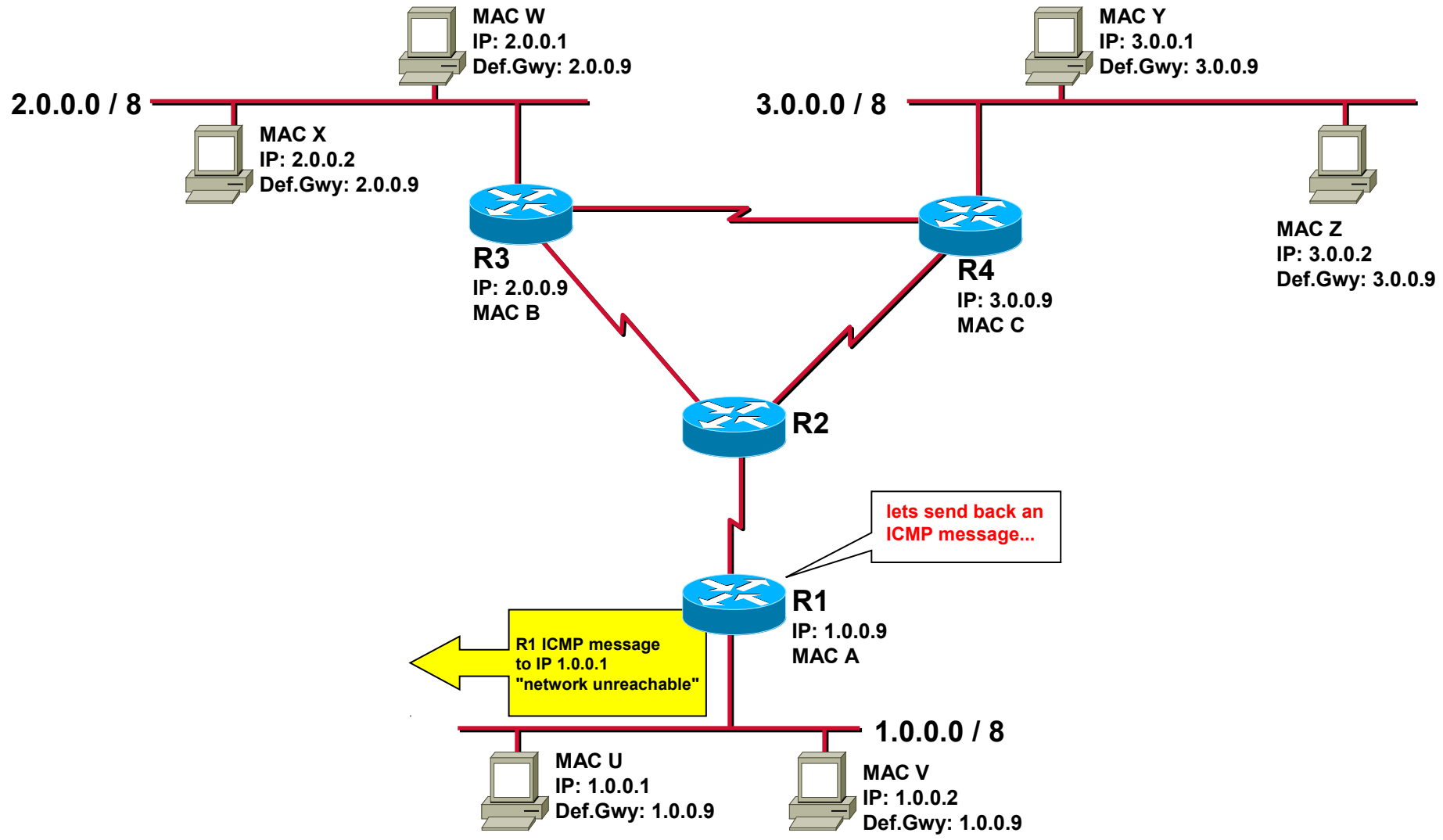

IP Forwarding und ICMP(2)

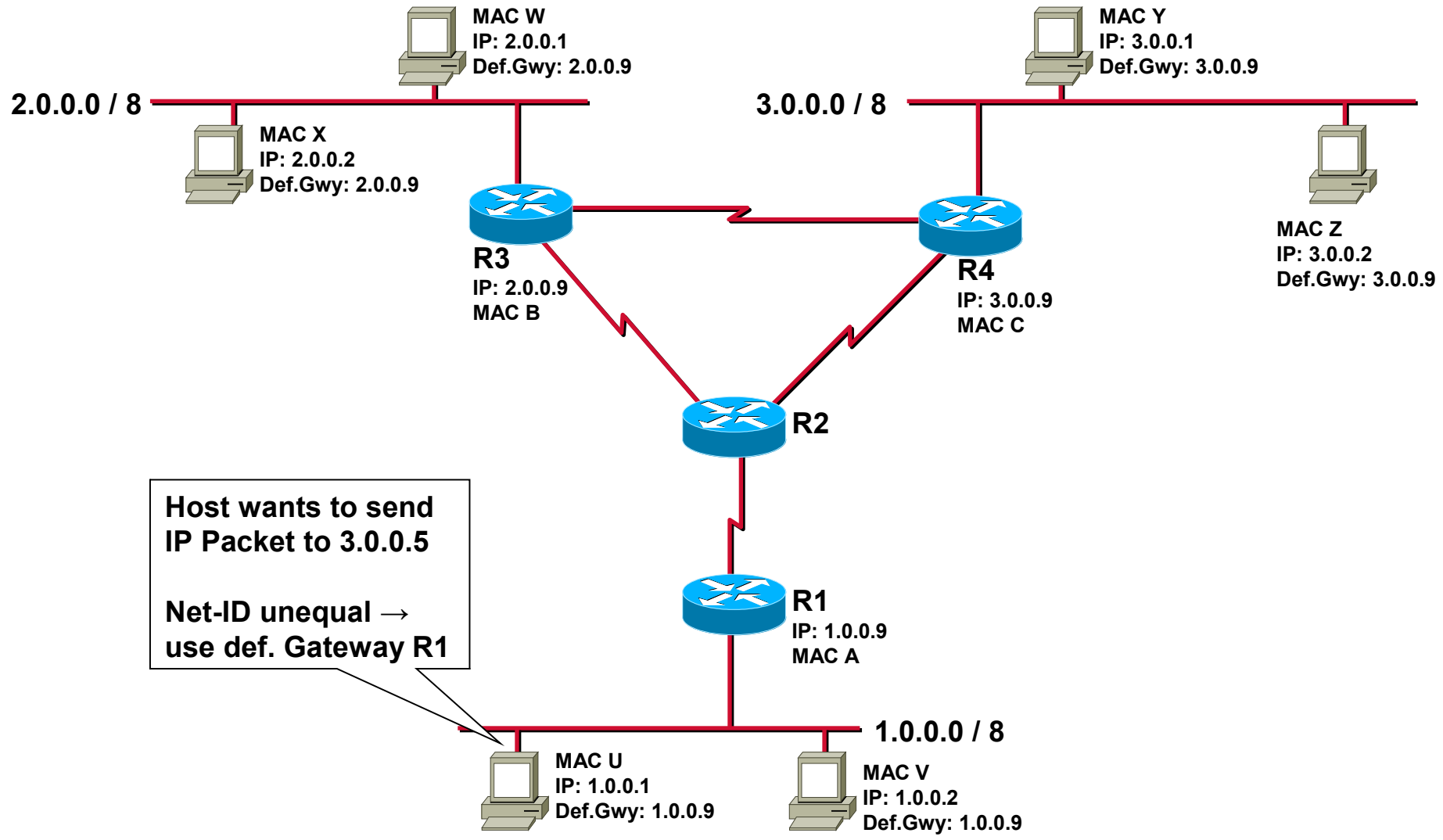

IP Forwarding und ICMP(2)

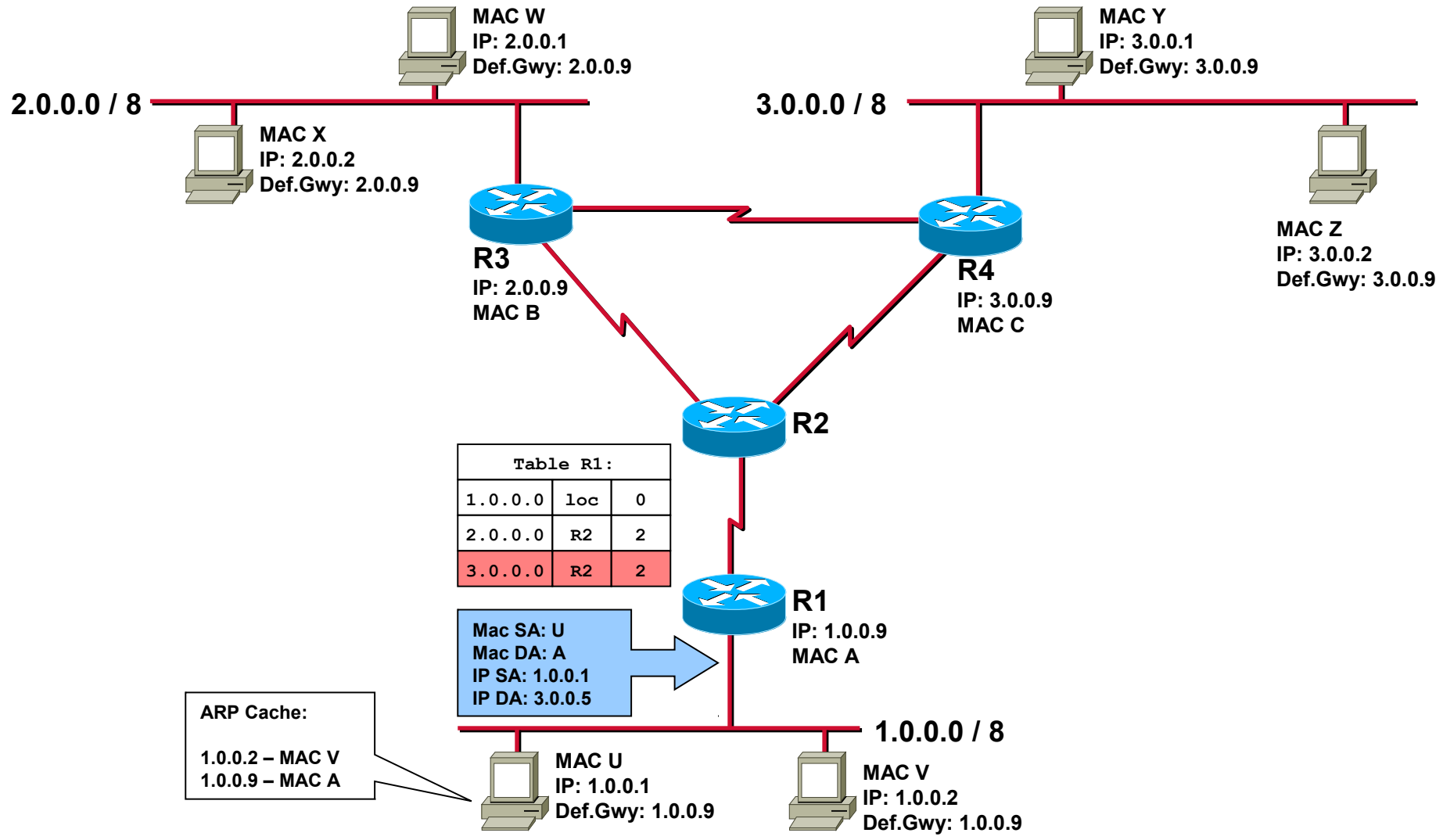

IP Forwarding und ICMP(2)

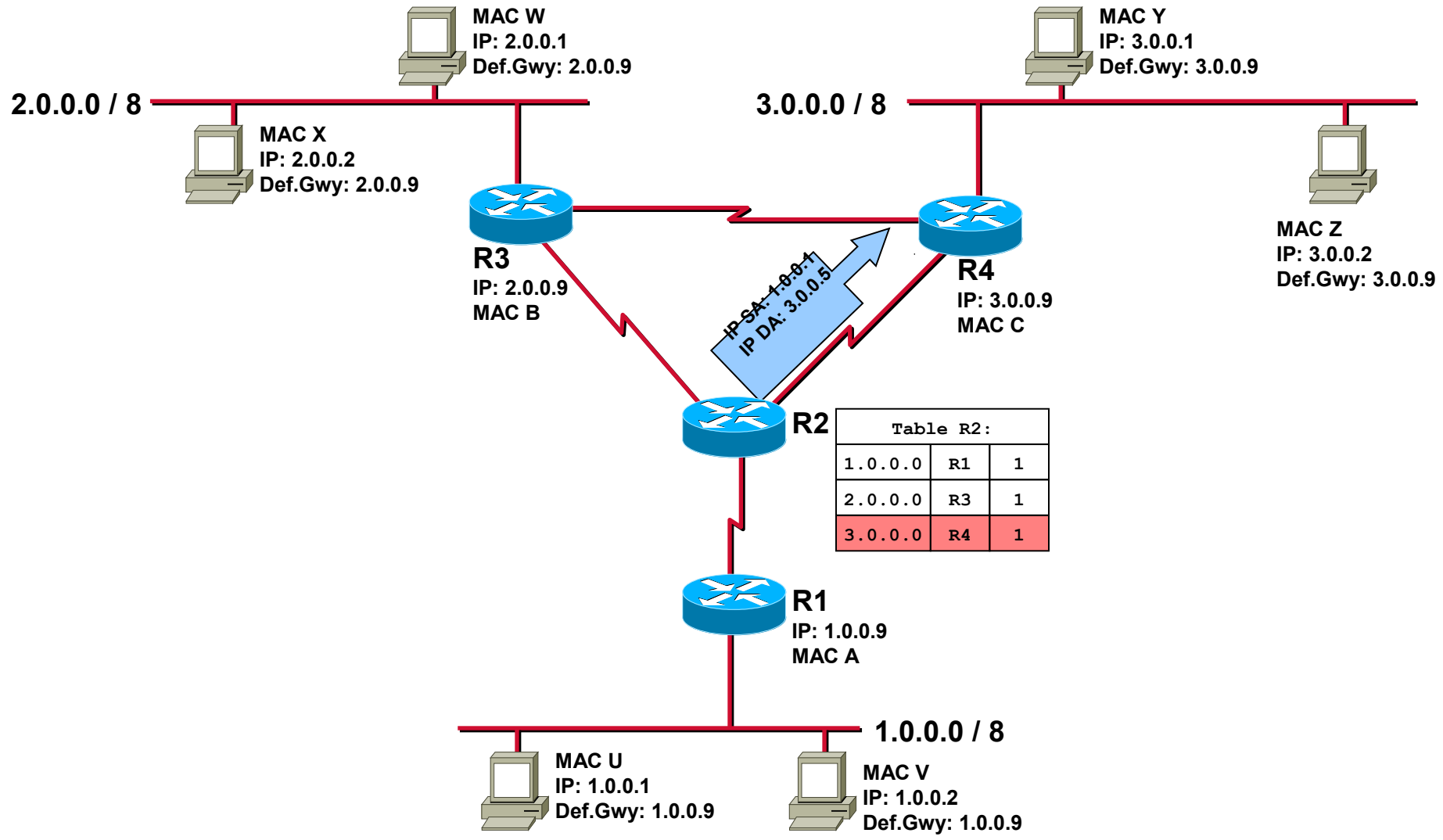

IP Forwarding und ICMP(2)

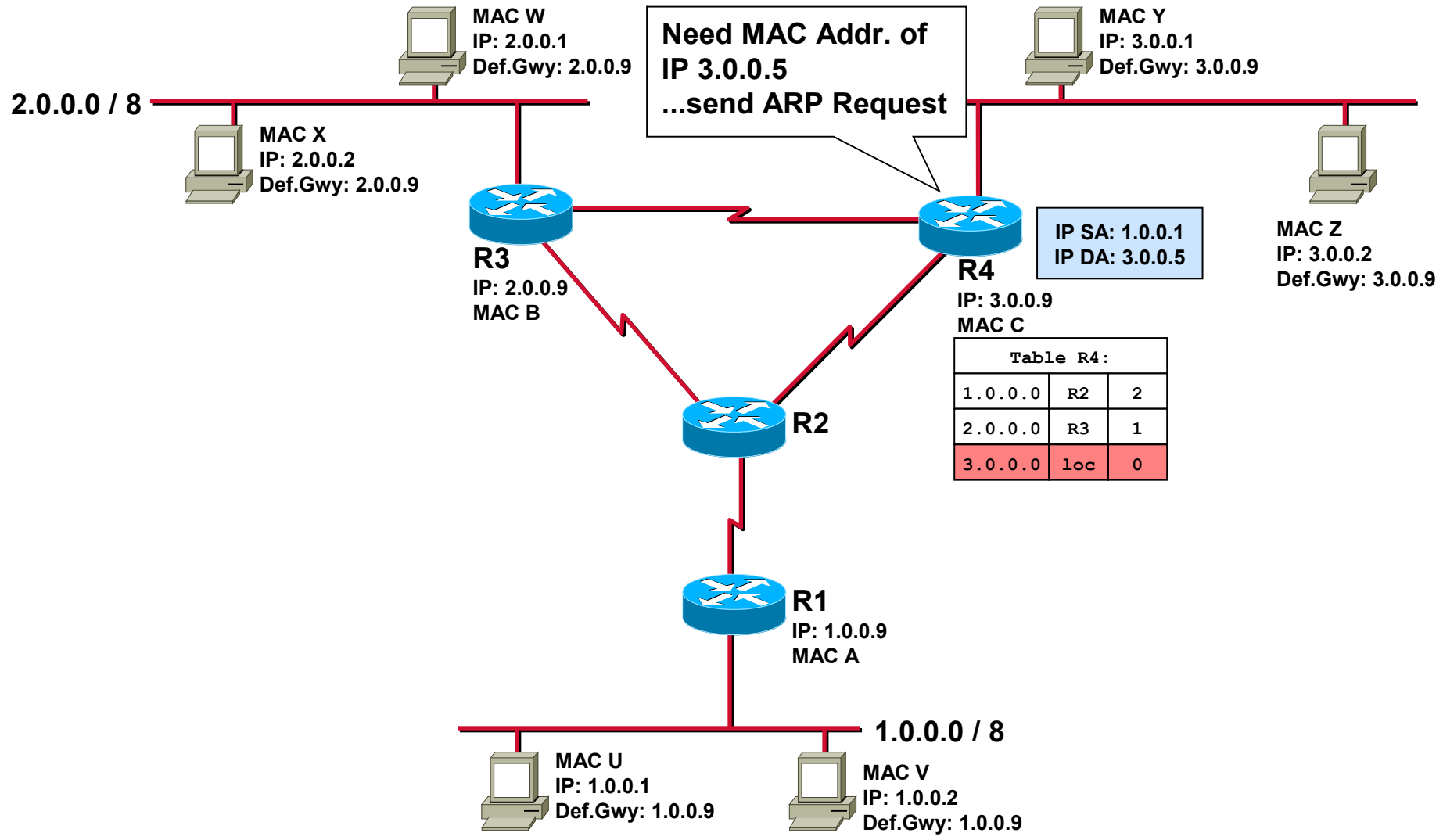

IP Forwarding und ICMP(2)

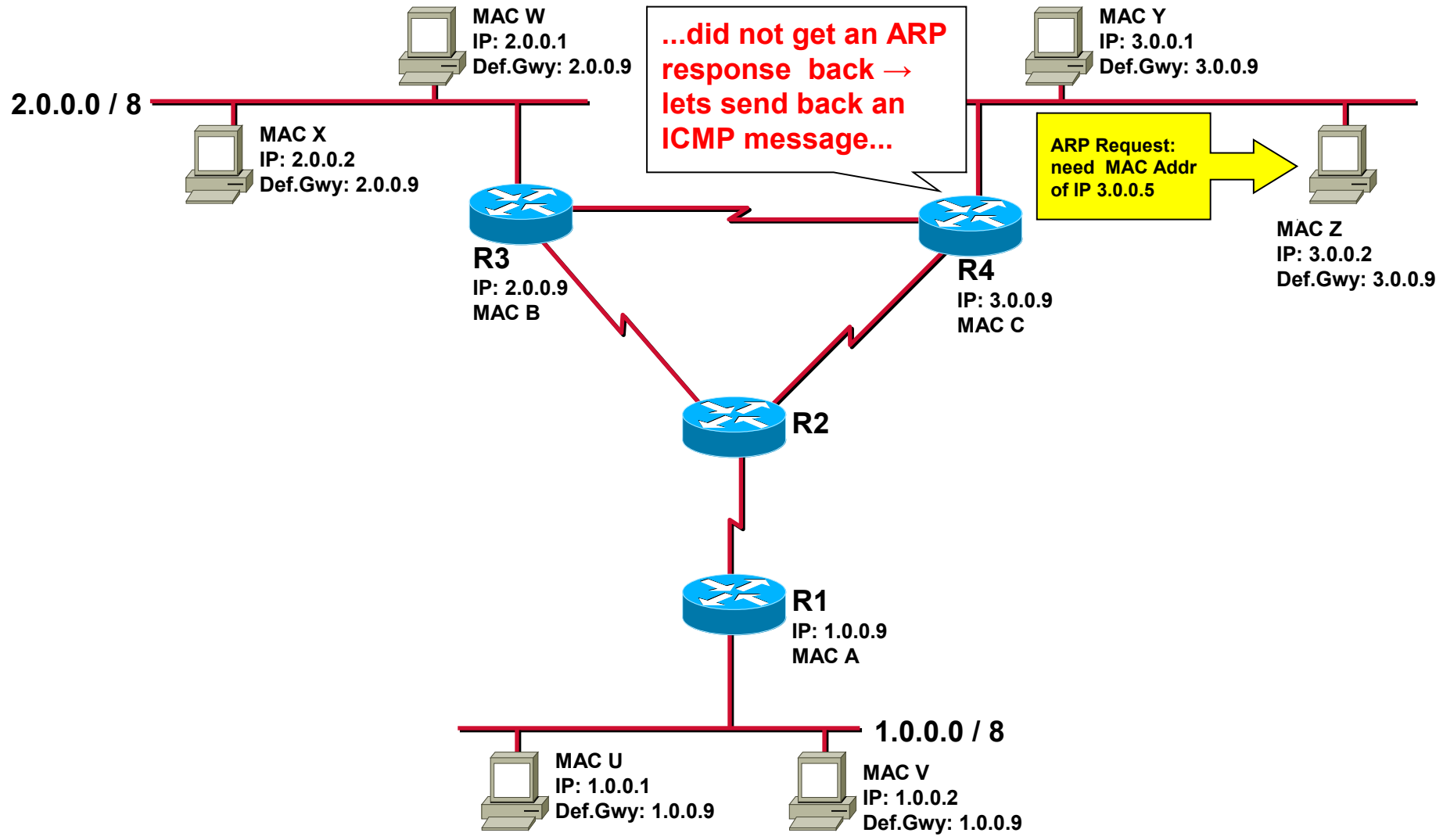

IP Forwarding und ICMP(2)

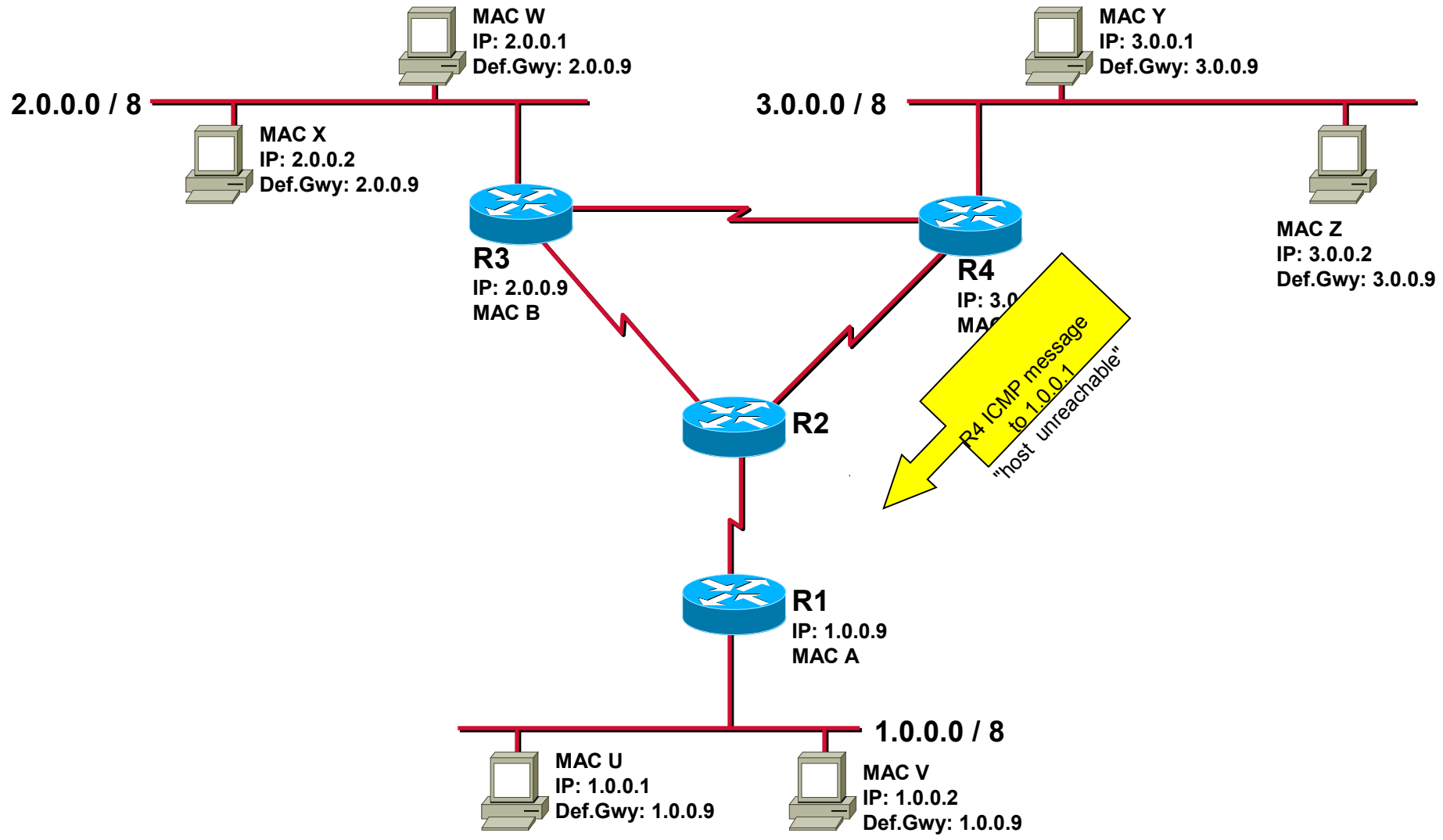

ICMP Redirect

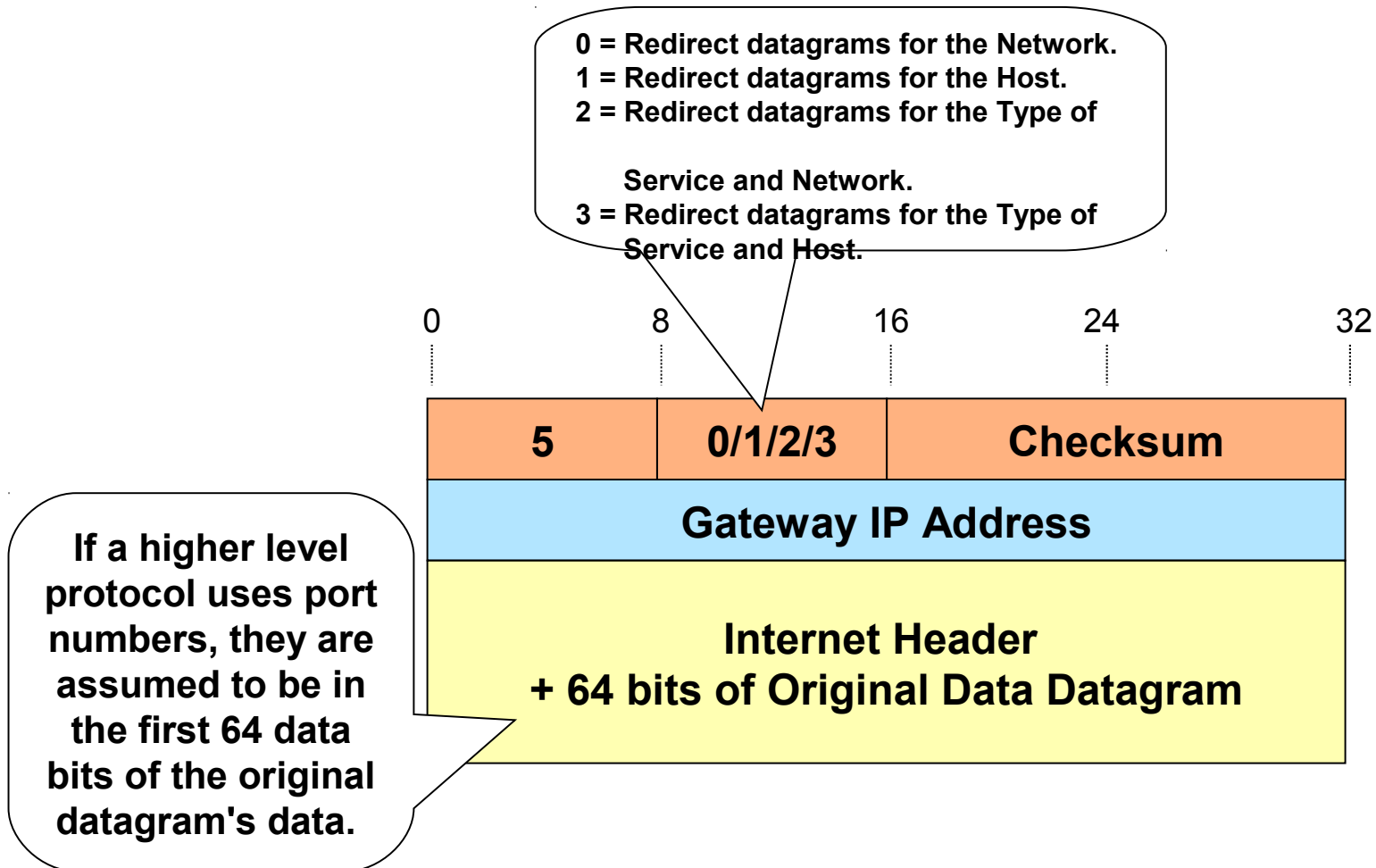



- The interface on which the packet comes into the router is the same interface on which the packet gets routed out
- The subnet/network of the source IP address is the same subnet/network of the next-hop IP address of the routed packet
- The datagram is **not source-routed**
- The kernel is configured to send redirects

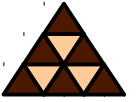

- **On Layer 3, IP-Addresses are used to route packets**
 - ◆ On Layer 2 different addresses are used (e.g. MAC-Address)
 - ◆ Mapping/Resolution needed → ARP
- **ARP is mostly dynamic (static entries are possible)**
- **The other way round: RARP (BootP, DHCP)**
- **ICMP is used to inform the originating IP-Host about what happend with its IP Packet**
 - ◆ IP Stacks do not neccesarily listen to ICMP message
 - ◆ Could be one way to implement flow-control (ICMP - source quench)



- **Why is ARP not needed on serial lines?**
- **Why are ARP-Cache entries timing out?**
- **Why should you use DHCP instead of RARP?**
- **What happens if a router discards an ICMP message?**
- **Ever heard of "Inverse ARP"?**