

L14 - Multiprotocol Label Switching

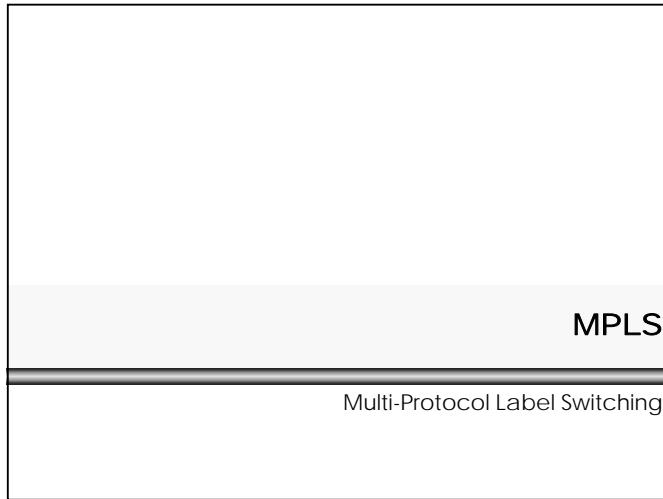

Agenda

- **Review ATM**
- **IP over WAN Problems (Traditional Approach)**
- **MPLS Principles**
- **Label Distribution Methods**
- **RFC's**

L14 - Multiprotocol Label Switching

ATM Scenario -> VPI / VCI

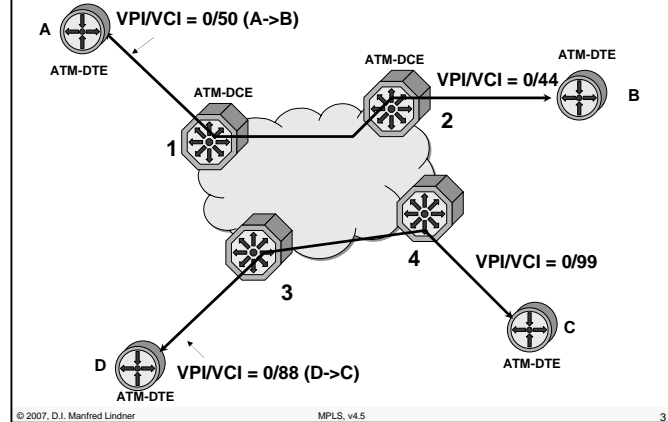

ATM Switching Tables

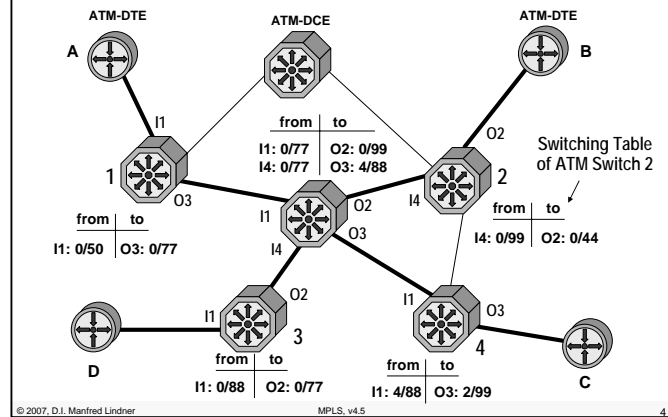

L14 - Multiprotocol Label Switching

Cell Forwarding / Label Swapping 1

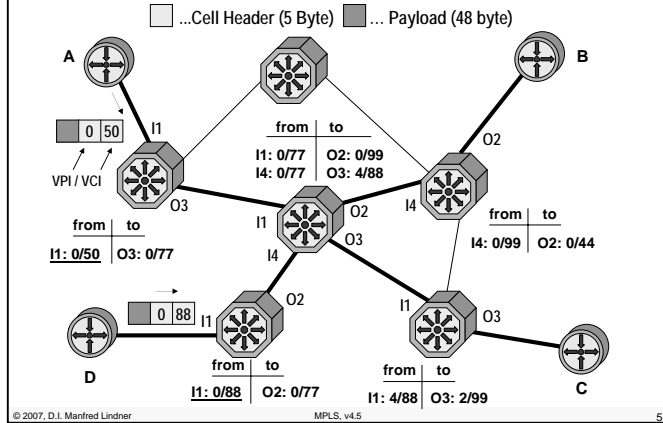

L14 - Multiprotocol Label Switching

Cell Forwarding / Label Swapping 3

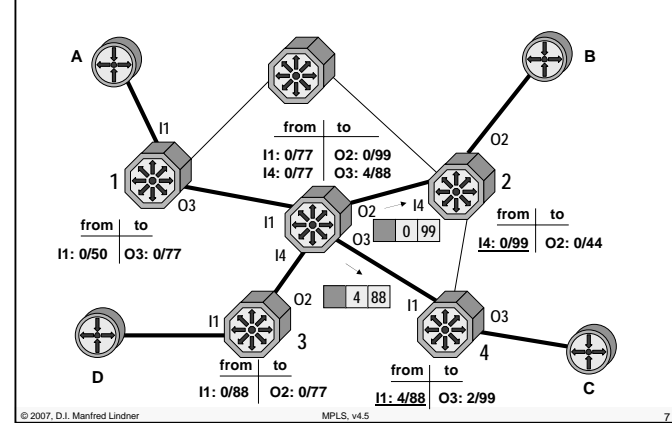

Cell Forwarding / Label Swapping 2

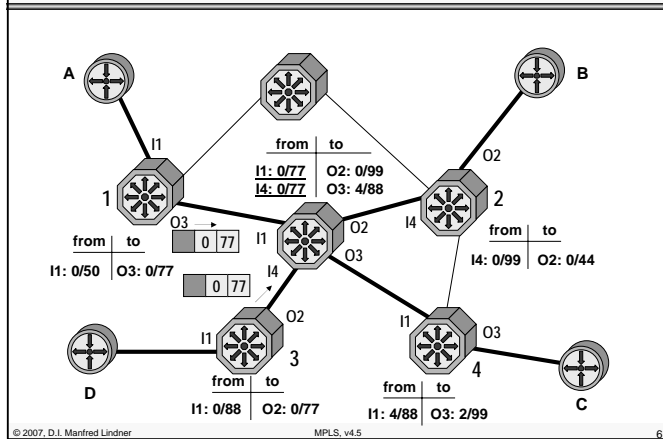

Cell Forwarding / Label Swapping 4

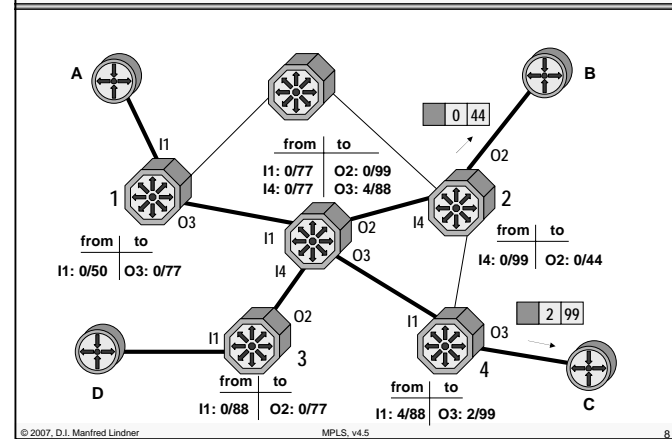

L14 - Multiprotocol Label Switching

Segmentation Principle

- **Cells are much smaller than data packets**
 - Segmentation and Reassembly is necessary in ATM DTE's (!!!)
 - ATM DCE's (ATM switches) are not involved in that

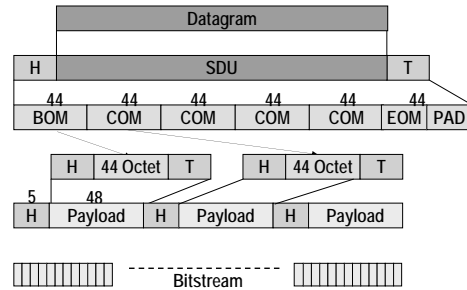

© 2007, D.I. Manfred Lindner MPLS, v4.5 9

ATM Routing in Private ATM Networks

- **PNNI is based on Link-State technique**
 - like OSPF
- **Topology database**
 - Every switch maintains a database representing the states of the links and the switches
 - Extension to link state routing !!!
 - Announce status of node (!) as well as status of links
 - Contains dynamic parameters like delay, available cell rate, etc. versus static-only parameters of OSPF (link up/down, node up/down, nominal bandwidth of link)
- **Path determination based on metrics**
 - Much more complex than with standard routing protocols because of ATM-inherent QoS support

© 2007, D.I. Manfred Lindner MPLS, v4.5 10

L14 - Multiprotocol Label Switching

PNNI Routing

- **Generic Connection Admission Control (GCAC)**
 - Used by the source switch to select a path through the network
 - Calculates the expected CAC (Connection Admission Control) behavior of another node

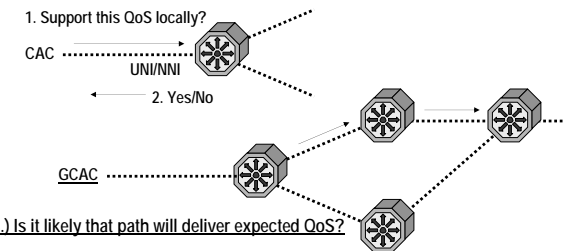

© 2007, D.I. Manfred Lindner MPLS, v4.5 11

PNNI Routing (Simple QoS -> ACR only)

- **Operation of the GCAC**
 - CR ... Cell Rate
 - ACR ... Available Cell Rate
 - D ... Distance like OSPF costs

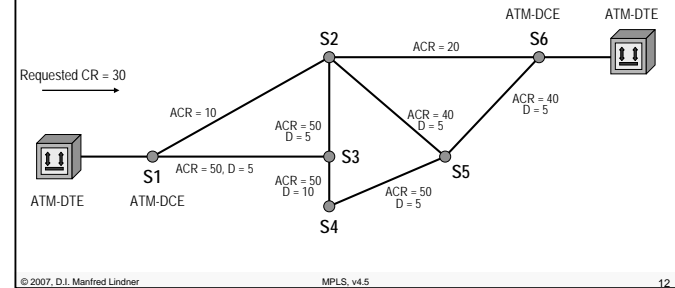

© 2007, D.I. Manfred Lindner MPLS, v4.5 12

L14 - Multiprotocol Label Switching

PNNI Routing

• Operation of the GCAC

- 1) Links not supporting requested CR are eliminated ->
- Metric component -> ACR value used

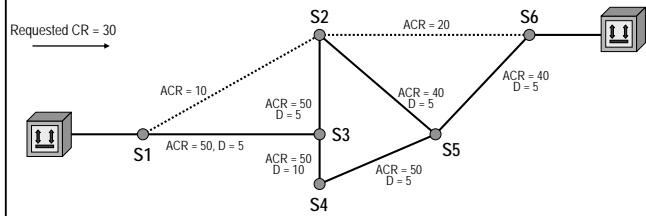

L14 - Multiprotocol Label Switching

PNNI Routing

• Operation of the GCAC

- 3) One path is chosen and source node S1 constructs a Designated Transit List (DTL) -> source routing --> -----
- Describes the complete route to the destination

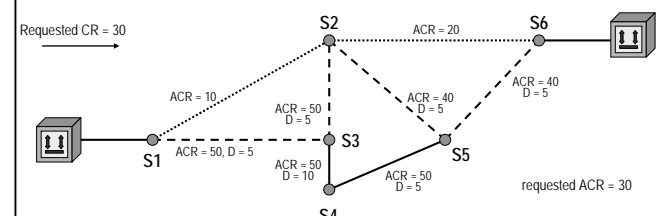

PNNI Routing

• Operation of the GCAC

- 2) Next, shortest path(s) to the destination is (are) calculated
- Metric component -> Distance value used

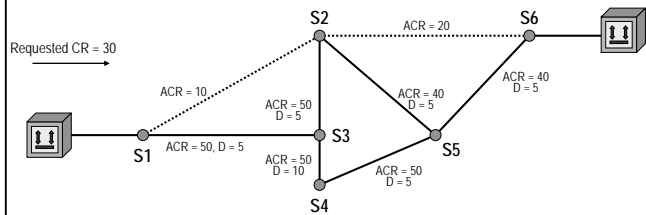

PNNI Routing - Source Routing

• Operation of the GCAC

- 4) DTL is inserted into signaling request and moved on to next switch
- 5) After receipt next switch perform local CAC
 - 5a) if ok -> pass PNNI signaling message on to next switch of DTL
- 6a) finally signaling request will reach destination ATM-DTE -> VC ok

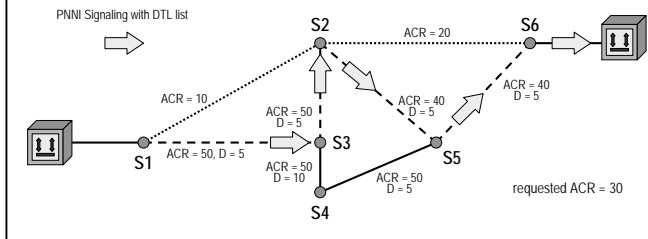

L14 - Multiprotocol Label Switching

PNNI Routing - Crankbank

• Operation of the GCAC

- 5) After receipt next switch (S2) perform local CAC
 - 5b) if nok -> return PNNI signaling message to originator of DTL
- 6b) S1 will construct alternate source route

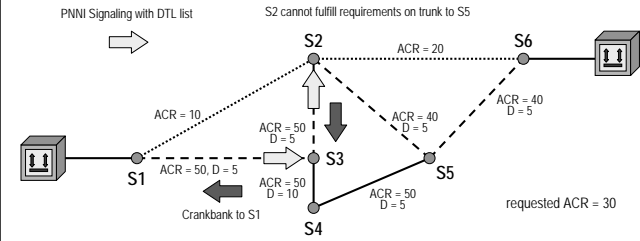

L14 - Multiprotocol Label Switching

PNNI Routing - Source Routing

• Operation of the GCAC

- 8b) DTL is inserted into signaling request
- 9b) After receipt next switch perform local CAC
 - if ok -> pass PNNI signaling message on to next switch of DTL
- 10b) finally signaling request will reach destination ATM-DTE -> VC ok

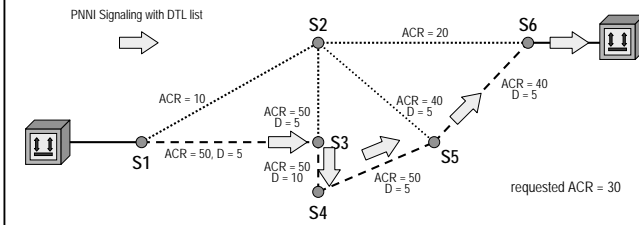

PNNI Routing - New Trial

• Operation after Crankbank

- 7b) The other possible path is chosen - source node constructs again a new Designated Transit List (DTL)

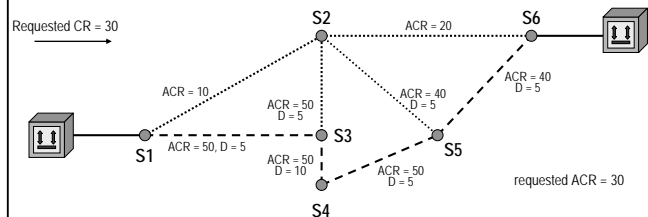

Agenda

- Review ATM
- IP over WAN Problems (Traditional Approach)
- MPLS Principles
- Label Distribution Methods
- RFC's

L14 - Multiprotocol Label Switching

IP Overlay Model - Scalability

• Base problem Nr.1

- IP routing separated from ATM routing because of the normal IP overlay model
- no exchange of routing information between IP and ATM world
- leads to scalability and performance problems
 - many peers, configuration overhead, duplicate broadcasts
- note:
 - IP system requests virtual circuits from the ATM network
 - ATM virtual circuits are established according to PNNI routing
 - virtual circuits are treated by IP as normal point-to-point links
 - IP routing messages are transported via this point-to-point links to discover IP neighbors and IP network topology

© 2007, D.I. Manfred Lindner

MPLS, v4.5

21

L14 - Multiprotocol Label Switching

IP Data Link View (Non-NBMA)

Every virtual circuit has its own IP Net-ID (subinterface technique)

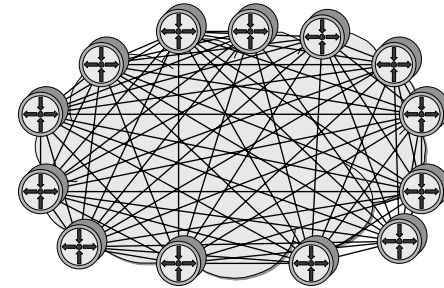

© 2007, D.I. Manfred Lindner

MPLS, v4.5

23

A Simple Physical Network ...

Physical wiring

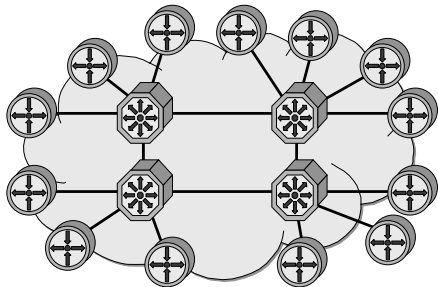

© 2007, D.I. Manfred Lindner

MPLS, v4.5

22

A Single Network Failure ...

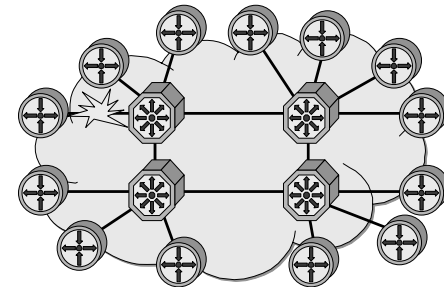

© 2007, D.I. Manfred Lindner

MPLS, v4.5

24

L14 - Multiprotocol Label Switching

Causes Loss of Multiple IP Router Peers !!!

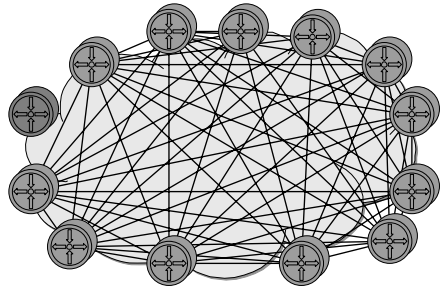

Example - Physical Topology

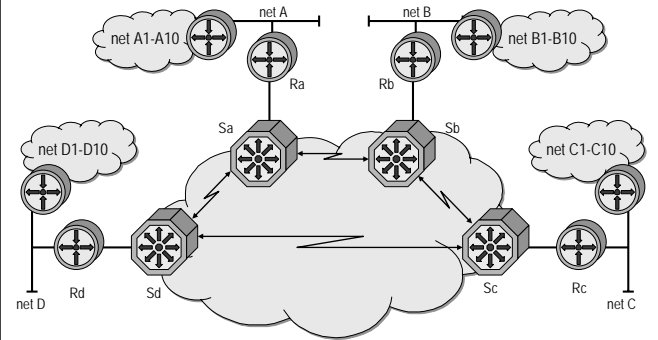

L14 - Multiprotocol Label Switching

IP Connectivity through Full-mesh VC's

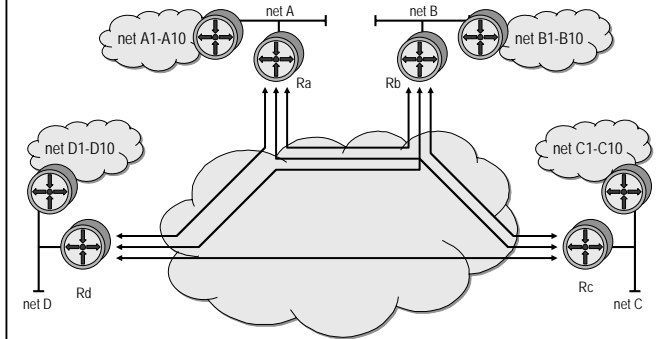

Static Routing/No Routing Broadcasts

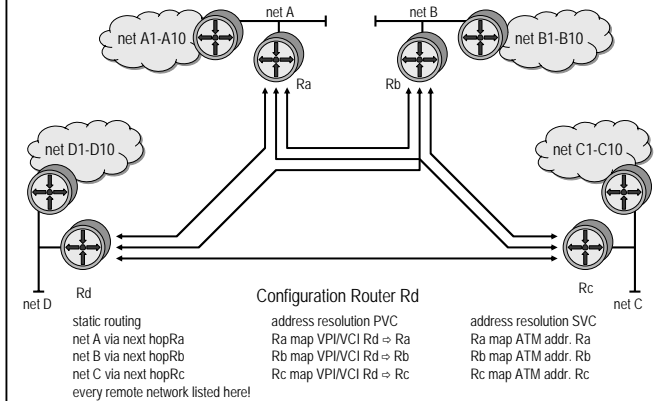

L14 - Multiprotocol Label Switching

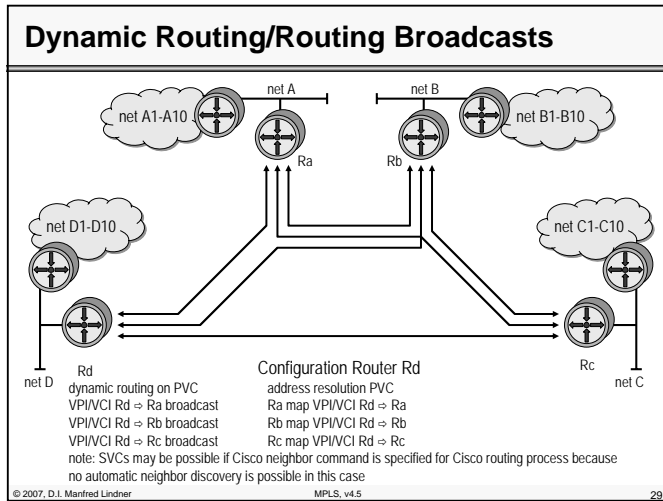

- ### Observations
- **This clearly does not scale**
 - **Switch/router interaction needed**
 - peering model
 - **Without MPLS**
 - Only outside routers are layer 3 neighbors
 - one ATM link failure causes multiple peer failures
 - routing traffic does not scale (number of peers)
 - **With MPLS**
 - Inside MPLS switch is the layer 3 routing peer of an outside router
 - one ATM link failure causes one peer failure
 - highly improved routing traffic scalability
- © 2007, D.I. Manfred Lindner MPLS, v4.5 30

L14 - Multiprotocol Label Switching

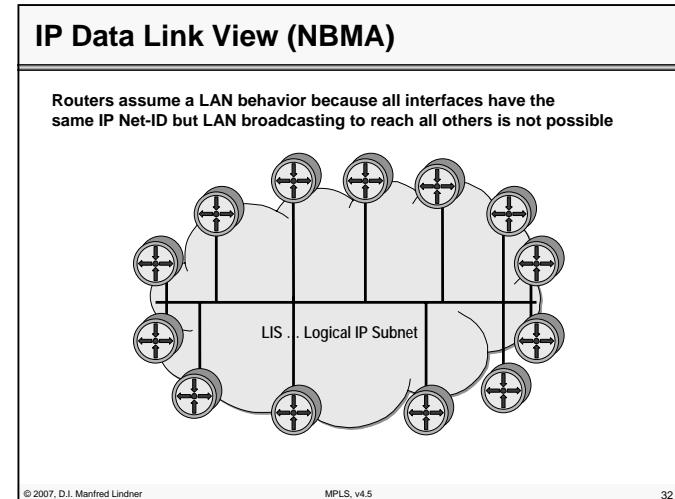
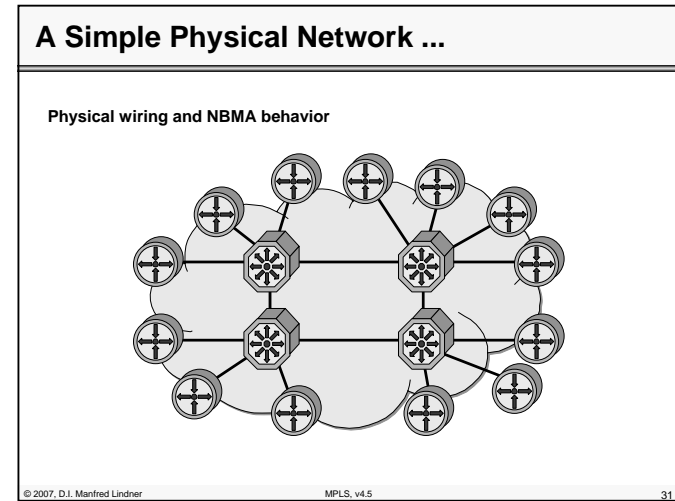

L14 - Multiprotocol Label Switching

Some Solutions for the NBMA Problem

- ARP (Address Resolution Protocol) Server
 - keeps configuration overhead for address resolution small
 - but does not solve the routing issue (neighbor discovery and duplicate routing broadcasts on a single wire)
- MARS/MCS (Multicast Address Resolution Server / Multicast Server)
 - additional keeps configuration overhead for routing small
 - but does not solve the duplicate broadcast problem
- LANE (LAN Emulation = ATM VLAN's)
 - simulates LAN behavior where address resolution and routing broadcasts are not a problem
- All of them
 - require a lot of control virtual circuits (p-t-p and p-t-m) and SVC support of the underlying ATM network

L14 - Multiprotocol Label Switching

MARS/MCS Architecture

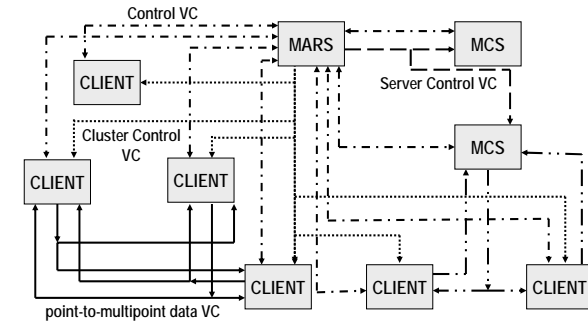

RFC 2225 Operation (Classical IP over ATM)

- **ARP server for every LIS**
 - multiple hops for communication between Logical IP Subnets

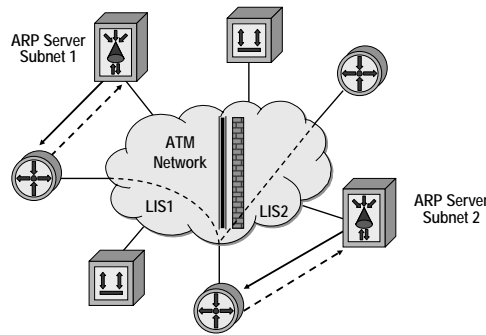

LANE Connections

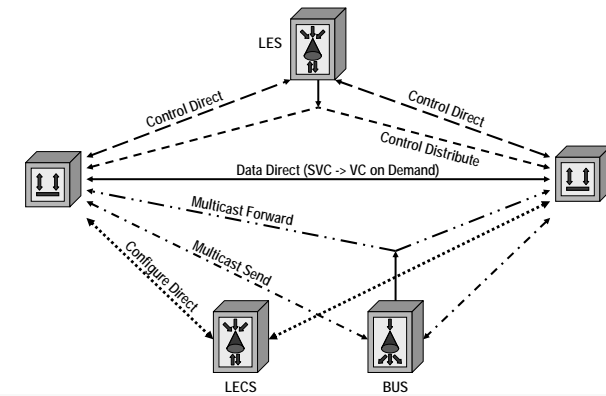

L14 - Multiprotocol Label Switching

Scalability Aspects

- **Number of IP peers determines**
 - number of data virtual circuits
 - number of control virtual circuits
 - number of duplicate broadcasts on a single wire
- **Method to solve the duplicate broadcast problem**
 - split the network in several LIS (logical IP subnets)
 - connect LIS's by normal IP router (ATM-DCE) which is of course outside the ATM network
- **But then another problem arise**
 - traffic between two systems which both are attached to the ATM network but belong to different LIS's must leave the ATM network and enter it again at the connecting IP router (-> SAR delay)

© 2007, D.I. Manfred Lindner

MPLS, v4.5

37

L14 - Multiprotocol Label Switching

Some Solutions for the ROLC Problem

- **NHRP (Next Hop Resolution Protocol)**
 - creates an ATM shortcut between two systems of different LIS's
- **MPOA (Multi Protocol Over ATM)**
 - LANE + NHRP combined
 - creates an ATM shortcut between two systems of different LIS's
- **In both methods**
 - the ATM shortcut is created if traffic between the two systems exceeds a certain threshold -> data-flow driven
 - a lot of control virtual circuits (p-t-p and p-t-m) is required

© 2007, D.I. Manfred Lindner

MPLS, v4.5

39

IP Multiple LIS's in case of ROLC (Routing over Large Clouds)

IP router A connects LIS1 and LIS2

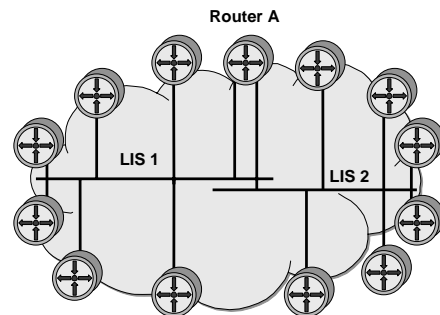

© 2007, D.I. Manfred Lindner

MPLS, v4.5

38

Wish for Optimized Connectivity

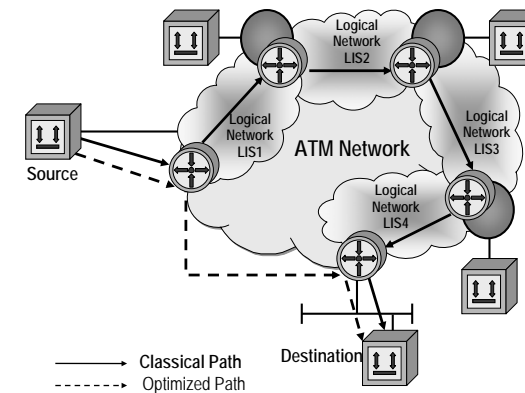

© 2007, D.I. Manfred Lindner

MPLS, v4.5

40

L14 - Multiprotocol Label Switching

Next Hop Resolution Protocol (RFC 2332)

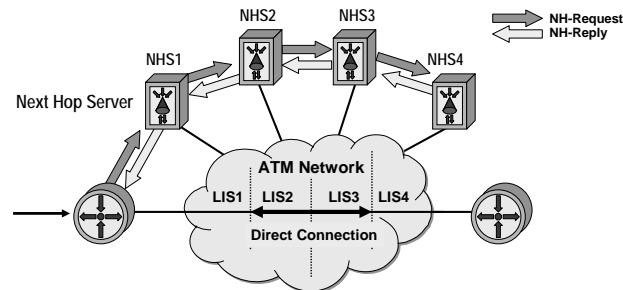

- **Next hop requests are passed between next hop servers**
 - Next hop servers do not forward data
- **NHS that knows about the destination sends back a NH-reply**
 - Allows direct connection between logical IP subnets across the ATM cloud
 - Separates data forwarding path from reachability information

© 2007, D.I. Manfred Lindner

MPLS, v4.5

41

IP Performance

• **Base problem Nr.2**

- IP forwarding is slow compared to ATM cell forwarding
 - IP routing paradigm
 - hop-by-hop routing with (recursive) IP routing table lookup, IP TTL decrement and IP checksum computing
 - destination based routing (large tables in the core of the Internet)
- Load balancing
 - in a stable network all IP datagram's will follow the same path (least cost routing versus ATM's QoS routing)
- QoS (Quality of Service)
 - IP is connectionless packet switching (best-effort delivery versus ATM's guarantees)
- VPN (Virtual Private Networks)
 - ATM VC's have a natural closed user group (=VPN) behavior

© 2007, D.I. Manfred Lindner

MPLS, v4.5

42

L14 - Multiprotocol Label Switching

Basic Ideas to Solve the Problems

- **Make ATM topology visible to IP routing**
 - to solve the scalability problems
 - an ATM switch gets IP router functionality
- **Divide IP routing from IP forwarding**
 - to solve the performance problems
 - IP forwarding based on ATM's label swapping paradigm (connection-oriented packet switching)
- **Combine best of both**
 - forwarding based on ATM label swapping paradigm
 - routing done by traditional IP routing protocols

© 2007, D.I. Manfred Lindner

MPLS, v4.5

43

MPLS

• **Several similar technologies were invented in the mid-1990s**

- IP Switching (Ipsilon)
- Cell Switching Router (CSR, Toshiba)
- Tag Switching (Cisco)
- Aggregated Route-Based IP Switching (ARIS, IBM)

• **IETF merges these technologies**

- MPLS (Multi Protocol Label Switching)
 - note: multiprotocol means that IP is just one possible protocol to be transported by a MPLS switched network
- RFC 3031

© 2007, D.I. Manfred Lindner

MPLS, v4.5

44

L14 - Multiprotocol Label Switching

MPLS Building Blocks

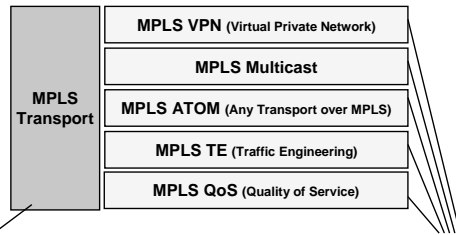

You always need this!
MPLS Transport solves most
of the mentioned problems
(scalability / performance)

If you need "Advanced Features like VPN or
Multicast support you optionally may choose
from these building blocks riding on top of
a MPLS Transport network

© 2007, D.I. Manfred Lindner

MPLS, v4.5

45

Agenda

- Review ATM
- IP over WAN Problems (Traditional Approach)
- **MPLS Principles**
- Label Distribution Methods
- RFC's

© 2007, D.I. Manfred Lindner

MPLS, v4.5

46

L14 - Multiprotocol Label Switching

MPLS Approach

- **Traditional IP uses the same information for**
 - path determination (routing)
 - packet forwarding (switching)
- **MPLS separates the tasks**
 - L3 addresses used for path determination
 - labels used for switching
- **MPLS Network consists of**
 - MPLS Edge Routers and MPLS Switches
- **Edge Routers and Switches**
 - exchange routing information about L3 IP networks
 - exchange forwarding information about the actual usage of labels

© 2007, D.I. Manfred Lindner

MPLS, v4.5

47

MPLS Network

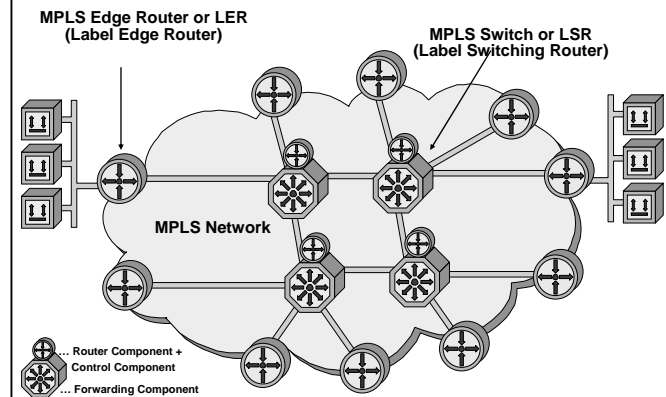

© 2007, D.I. Manfred Lindner

MPLS, v4.5

48

L14 - Multiprotocol Label Switching

MPLS LSR Internal Components

- **Routing Component**
 - still accomplished by using standard IP routing protocols creating routing table
- **Control Component**
 - maintains correct label distribution among a group of label switches
 - Label Distribution Protocol for communication
 - between MPLS Switches
 - between MPLS Switch and MPLS Edge Router
- **Forwarding Component**
 - uses labels carried by packets plus label information maintained by a label switch (switching table) to perform packet forwarding -> “label swapping”

L14 - Multiprotocol Label Switching

Generic Overview of MPLS LSR Internal Processes and Communication

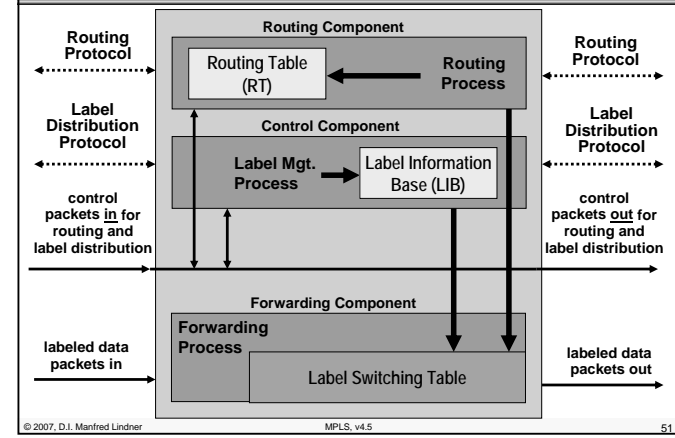

MPLS Control Communication

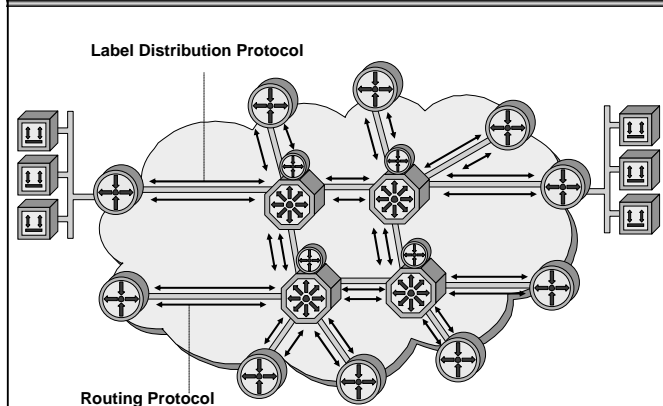

MPLS Basic Operations

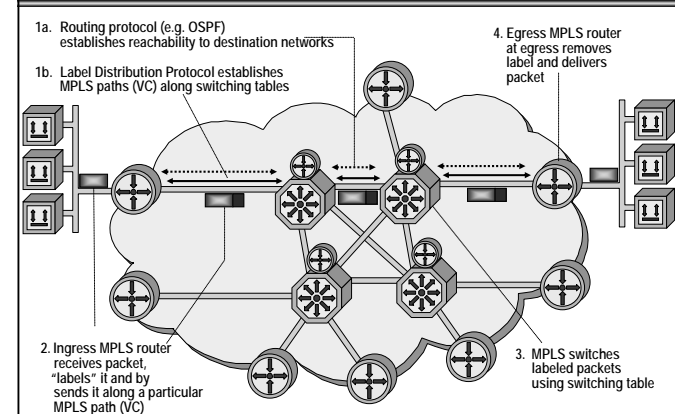

L14 - Multiprotocol Label Switching

MPLS Header: Frame Mode

- "Layer 2.5" can be used over Ethernet, 802.3 or PPP links
 - note: 2.5 means 32 bit
 - 20-bit MPLS label (Label)
 - 3-bit experimental field (Exp)
 - could be copy of IP Precedence -> MPLS QoS like IP QoS with DiffServ Model based on DSCP
 - 1-bit bottom-of-stack indicator (S)
 - Labels could be stacked (Push & Pop)
 - MPLS switching performed always on the first label of the stack
 - 8-bit time-to-live field (TTL)

© 2007, D.I. Manfred Lindner MPLS, v4.5 53

L14 - Multiprotocol Label Switching

Labels and FEC

- **A label is used to identify a certain subset of packets**
 - which take the same MPLS path or which get the same forwarding treatment in the MPLS label switched network
 - The path is so called Label Switched Path (LSP)
 - "The MPLS Virtual Circuit"
- **Thus a label represents**
 - a so called Forwarding Equivalence Class (FEC)
- **The assignment of a packet to FEC**
 - is done just once by the MPLS Edge Router, as the packet enters the network
 - most commonly is based on the network layer destination address

© 2007, D.I. Manfred Lindner MPLS, v4.5 55

MPLS Header: Cell Mode

ATM Convergence Sublayer (CS):

- **ATM Switches can only switch VPI/VCI—no MPLS labels!**
 - Only the topmost label is inserted in the VPI/VCI field

ATM Segmentation and Reassembling Sublayer (SAR):

(first cell)

GFC	VPI	VCI	PTI	CLP	HEC	MPLS Header(s)	IP Header	DATA
-----	-----	-----	-----	-----	-----	----------------	-----------	------

(subsequent cells)

GFC	VPI	VCI	PTI	CLP	HEC	DATA
-----	-----	-----	-----	-----	-----	------

© 2007, D.I. Manfred Lindner MPLS, v4.5 54

Label Binding

- **Two neighboring LSR's R1 and R2**
 - may agree that when R1 transmits a packet to R2, R1 will label with packet with label value L if and only if the packet is a member of a particular FEC F
- **They agree**
 - on a so called "binding" between label L and FEC F for packets moving from R1 to R2
- **As a result**
 - L becomes R1's "outgoing label" or "remote label" representing FEC F
 - L becomes R2's "incoming label" or "local label" representing FEC F

© 2007, D.I. Manfred Lindner MPLS, v4.5 56

L14 - Multiprotocol Label Switching

Creating and Destroying Label Binding 1

- **Control Driven (favored by IETF-WG)**
 - creation or deconstruction of labels is triggered by control information such as
 - OSPF routing
 - PIM Join/Prune messages in case of IP multicast routing
 - IntSrv RSVP messages in case of IP QoS IntSrv Model
 - DiffSrv Traffic Engineering in case of IP QoS DiffSrv Model
 - hence we have a pre-assignment of labels based on reachability information
 - and optionally based on QoS needs
 - also called Topology Driven

Creating and Destroying Label Binding 2

- **Data Driven**
 - creation or deconstruction of labels is triggered by data packets
 - but only if a critical threshold number of packets for a specific communication relationship is reached
 - may have a big performance impact
 - hence we have dynamic assignment of labels based on data flow detection
 - also called Traffic Driven

L14 - Multiprotocol Label Switching

Some FEC Examples for Topology Driven

- **FEC's could be for example**
 - a set of unicast packets whose network layer destination address matches a particular IP address prefix
 - MPLS application: Destination Based (Unicast) Routing
 - a set of multicast packets with the same source and destination network layer address
 - MPLS application: Multicast Routing
 - a set of unicast packets whose network layer destination address matches a particular IP address prefix and whose Type of Service (ToS) or DSCP bits are the same
 - MPLS application: Quality of Service
 - MPLS application: Traffic Engineering or Constraint Based Routing

Label Distribution

- **MPLS architecture allows an LSR to distribute bindings to LSR's that have not explicitly requested them**
 - "Unsolicited Downstream" label distribution
 - usually used by Frame-Mode MPLS
- **MPLS architecture allows an LSR to explicitly request, from its next hop for a particular FEC, a label binding for that FEC**
 - "Downstream-On-Demand" label distribution
 - must be used by Cell-Mode MPLS

L14 - Multiprotocol Label Switching

Label Binding

- **The decision to bind a particular label L to a particular FEC F**
 - is made by the LSR which is DOWNSTREAM with respect to that binding
 - the downstream LSR then informs the upstream LSR of the binding
 - thus labels are "downstream-assigned"
 - thus label bindings are distributed in the "downstream to upstream" direction
- **Discussion were about if**
 - labels should also be "upstream-assigned"
 - not any longer part of current MPLS-RFC

© 2007, D.I. Manfred Lindner

MPLS, v4.5

61

Label Retention Mode

1

- **A LSR may receive a label binding**
 - for a particular FEC from another LSR, which is not next hop based on the routing table for that FEC
- **This LSR then has the choice**
 - of whether to keep track of such bindings, or whether to discard such bindings
- **A LSR supports "Liberal Label Retention Mode"**
 - if it maintains the bindings between a label and a FEC which are received from LSR's which are not its next hop for that FEC

© 2007, D.I. Manfred Lindner

MPLS, v4.5

62

L14 - Multiprotocol Label Switching

Label Retention Mode

2

- **A LSR supports "Conservative Label Retention mode"**
 - If it discards the bindings between a label and a FEC which are received from LSR's which are not its next hop for that FEC
- **Liberal Label Retention mode**
 - allows for quicker adaptation to routing changes
 - LSR can switch over to next best LSP
- **Conservative Label Retention mode**
 - requires an LSR to maintain fewer labels
 - LSR has to wait for new label bindings in case of topology changes

© 2007, D.I. Manfred Lindner

MPLS, v4.5

63

Independent versus Ordered Control

- **Independent Control:**
 - each LSR may make an independent decision to assign a label to a FEC and to advertise the assignment to its neighbors
 - typically used in Frame-Mode MPLS for destination based routing
 - loop prevention must be done by other means (-> MPLS TTL) but there is faster convergence
- **Ordered Control:**
 - label assignment proceeds in an orderly fashion from one end of a LSP to the other
 - under ordered control, LSP setup may be initiated by the ingress (header) or egress (tail) MPLS Edge Router

© 2007, D.I. Manfred Lindner

MPLS, v4.5

64

L14 - Multiprotocol Label Switching

Ordered Control - Egress

- in case of egress method the only LSR which can initiate the process of label assignment is the egress LSR
- a LSR knows that it is the egress for a given FEC if its next hop for this FEC is not an LSR
- this LSR will send a label advertisement to all neighboring LSR's
- a neighboring LSR receiving such a label advertisement from a interface which is the next hop to a given FEC will assign its own label and advertise it to all other neighboring LSR's
- inherent loop prevention
- slower convergence

Ordered Control - Ingress

- in case of ingress method the LSR which initiates the process of label assignment is the ingress LSR
- the ingress LSR constructs a source route and pass on requests for label bindings to the next LSR
- this is done until LSR which is the end of the source route is reached
- from this LSR label bindings will flow upstream to the ingress LSR
- used for MPLS Traffic Engineering (TE)

L14 - Multiprotocol Label Switching

Agenda

- Review ATM
- IP over WAN Problems (Traditional Approach)
- MPLS Principles
- Label Distribution Methods
 - Unsolicited Downstream
 - Downstream On Demand
- RFC's

Routing Table Created by Routing Protocol

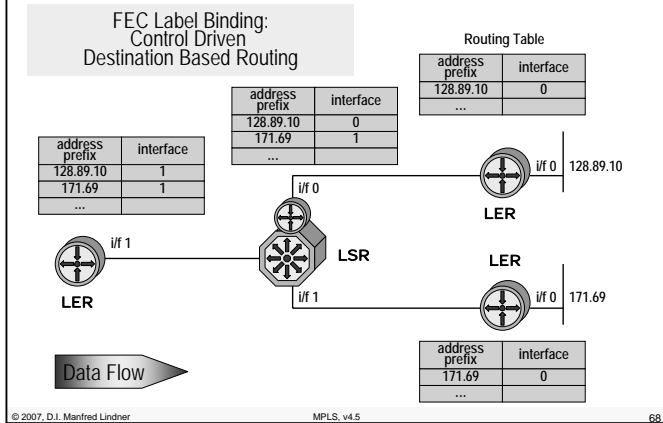

L14 - Multiprotocol Label Switching

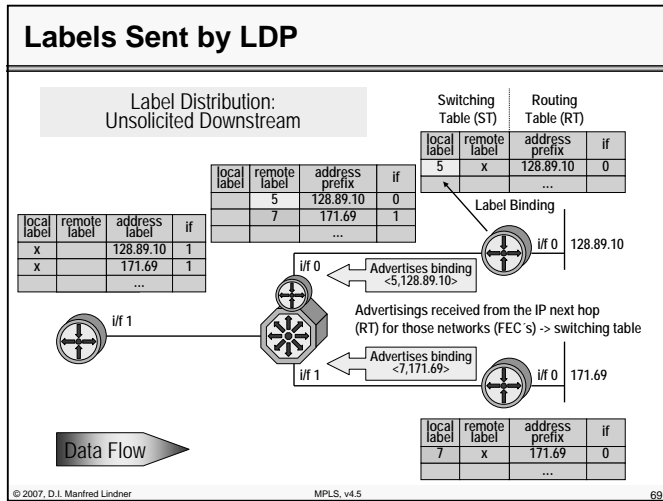

L14 - Multiprotocol Label Switching

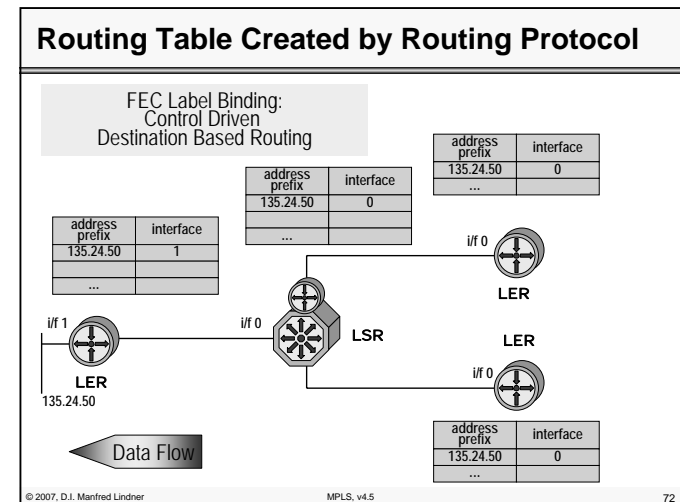
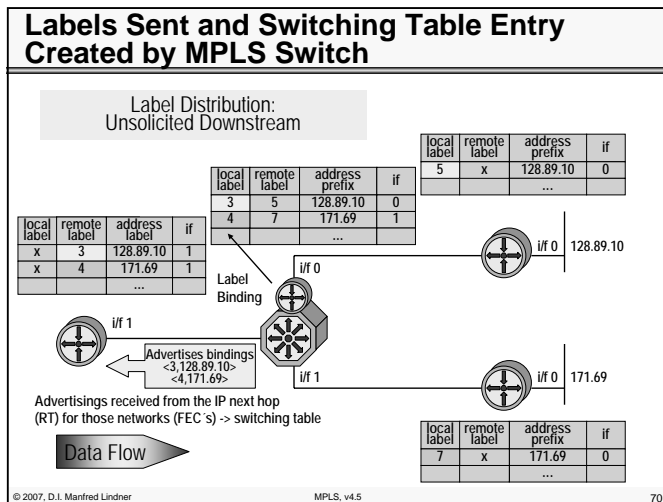
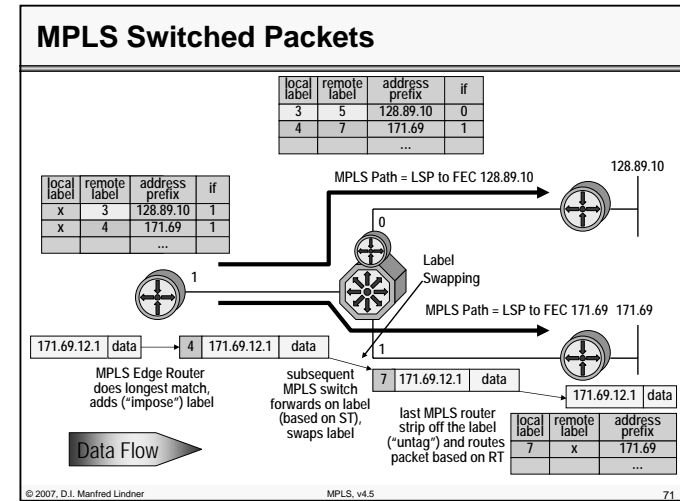

L14 - Multiprotocol Label Switching

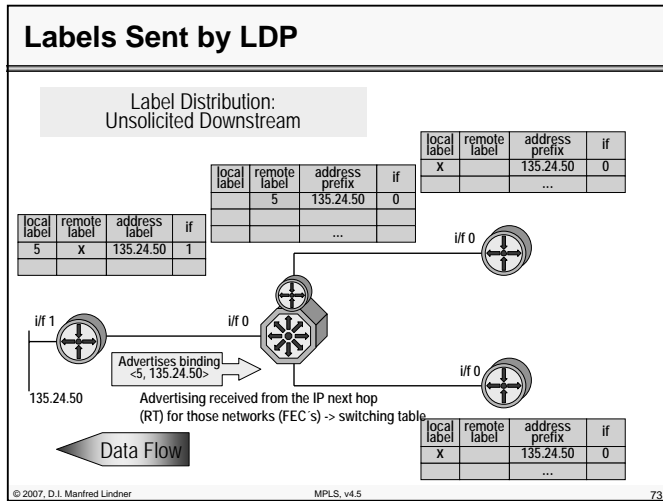

L14 - Multiprotocol Label Switching

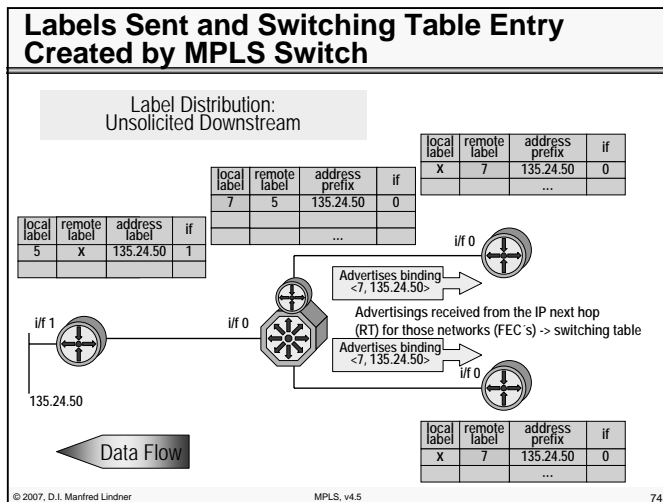
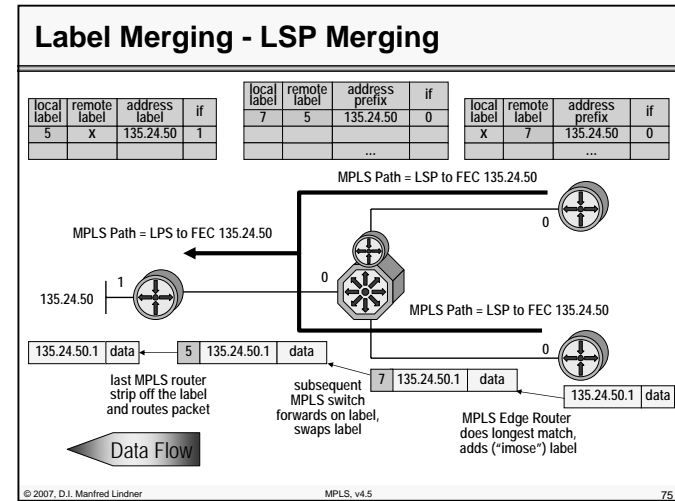

Agenda

- Review ATM
- IP over WAN Problems (Traditional Approach)
- MPLS Principles
- Label Distribution Methods
 - Unsolicited Downstream
 - Downstream On Demand
- RFC's

L14 - Multiprotocol Label Switching

Routing Table Created by Routing Protocol

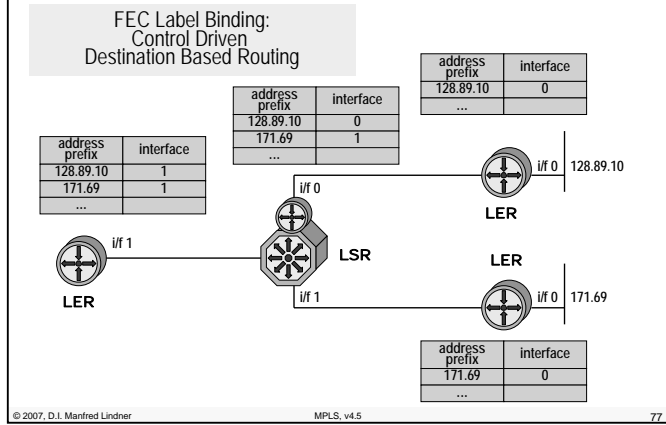

L14 - Multiprotocol Label Switching

Labels Requested by MPLS Switch

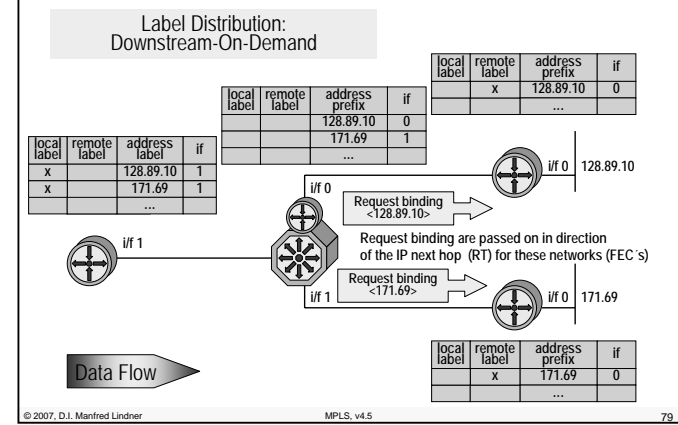

Labels Requested by MPLS Edge Routers

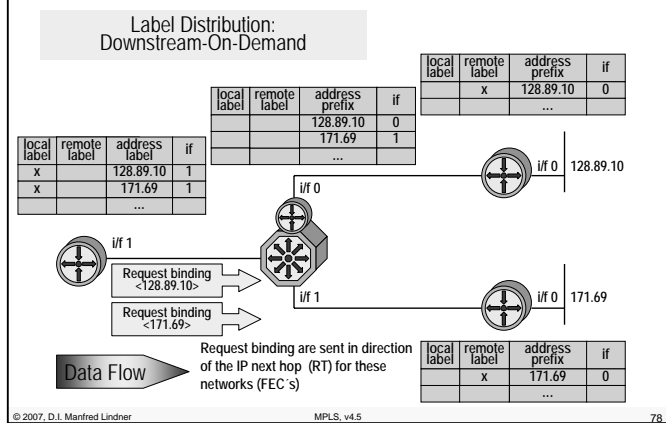

Labels Allocated by MPLS Edge Router

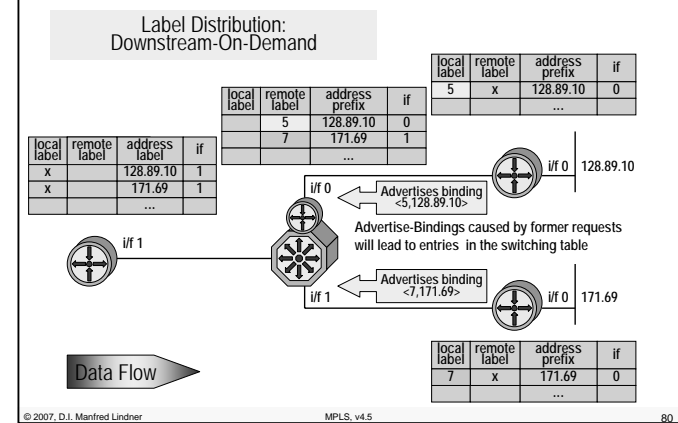

L14 - Multiprotocol Label Switching

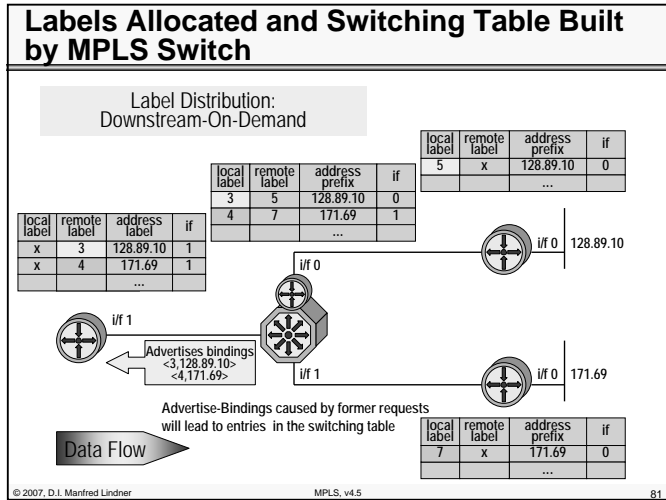

L14 - Multiprotocol Label Switching

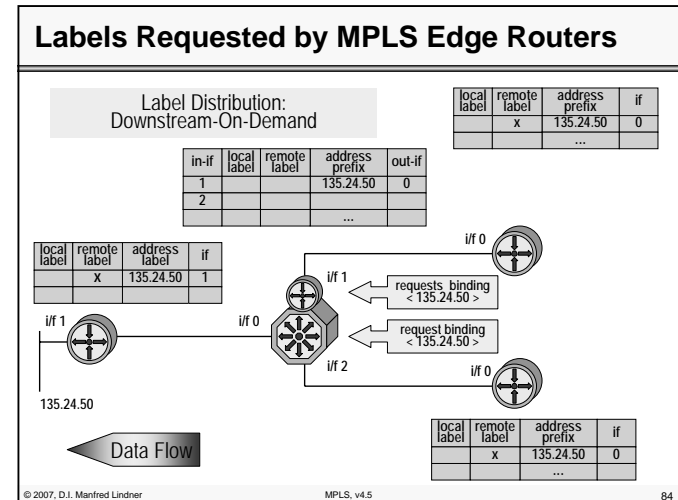
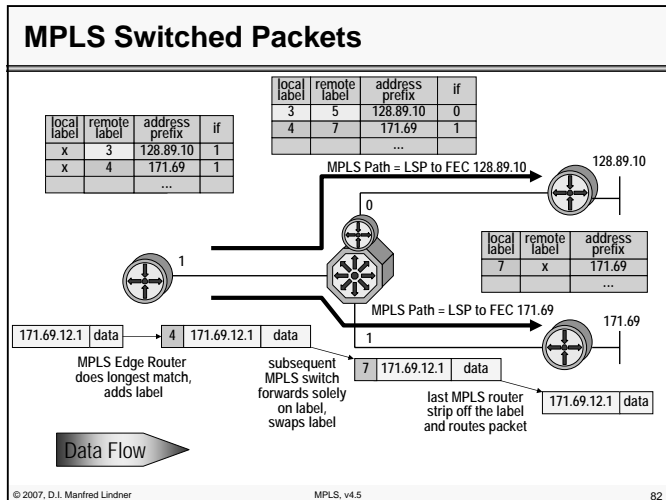
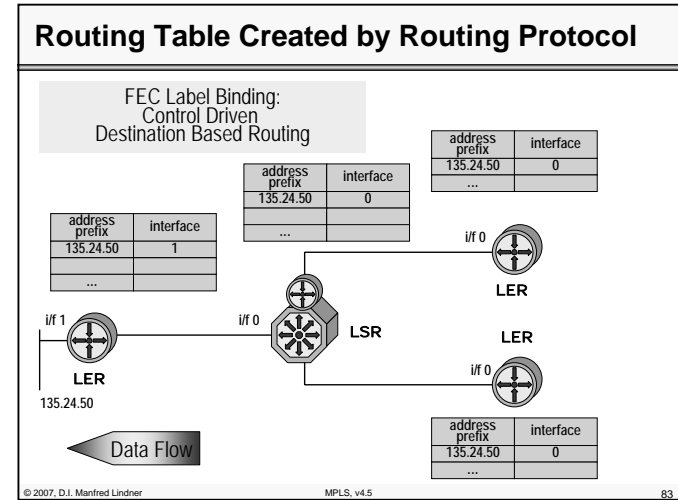

L14 - Multiprotocol Label Switching

Labels Requested by MPLS Switch

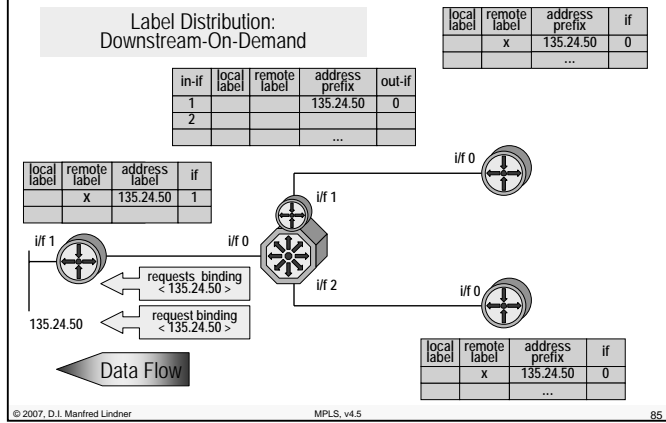

L14 - Multiprotocol Label Switching

Labels Allocated and Switching Table Built by MPLS Switch

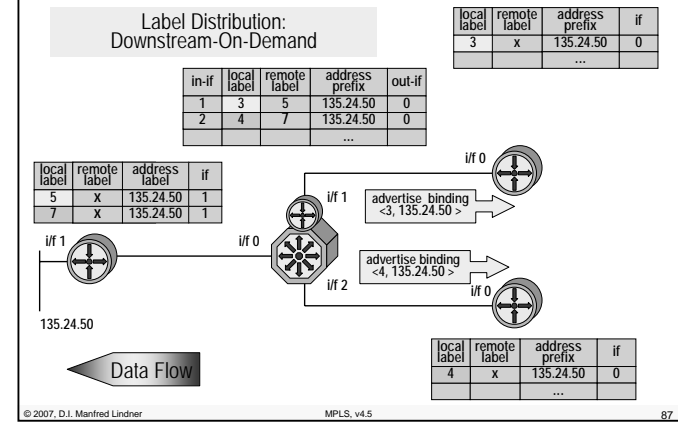

Labels Allocated by MPLS Edge Router

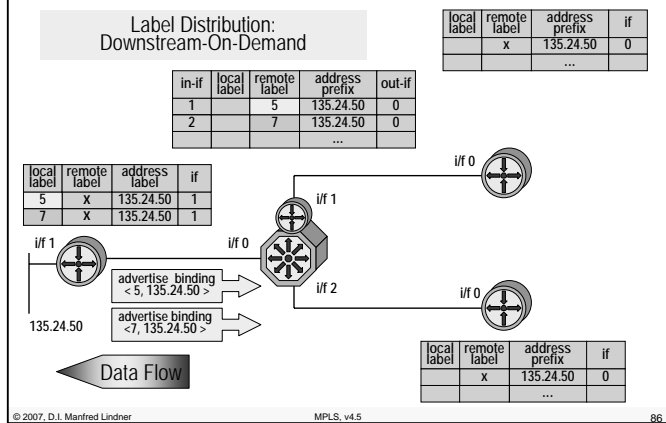

Two Separate LSP's

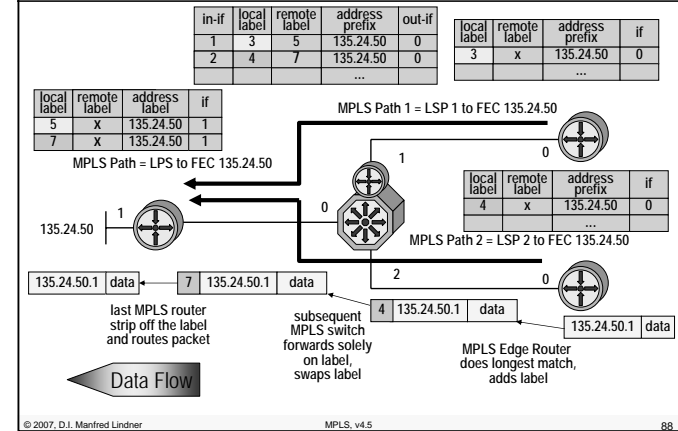

L14 - Multiprotocol Label Switching

Label Switching and ATM

- Can be easily deployed with ATM because ATM uses label swapping
 - VPI/VCI is used as a label
- ATM switches needs to implement control component of label switching
 - ATM attached router peers with ATM switch (label switch)
 - exchange label binding information
- Differences
 - how labels are set up
 - label distribution -> downstream on demand allocation
 - label merging
 - in order to scale, merging of multiple streams (labels) into one stream (label) is required

L14 - Multiprotocol Label Switching

Label Distribution Solution for ATM

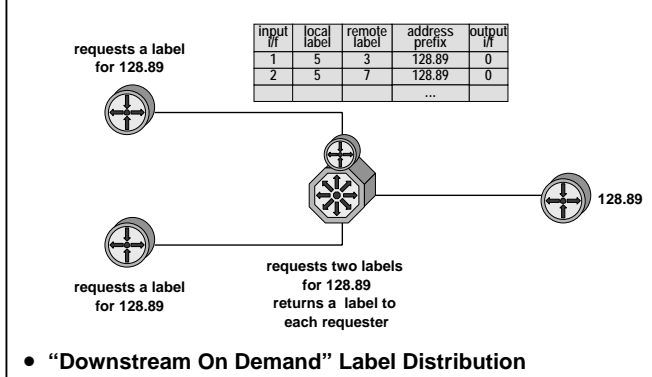

- “Downstream On Demand” Label Distribution

Label Switching and ATM

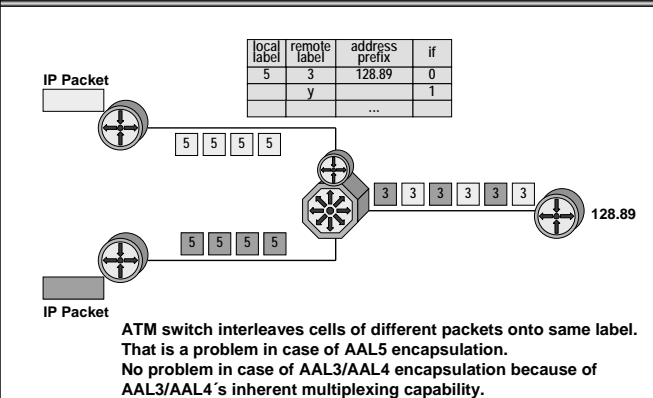

Label Distribution Solution for ATM

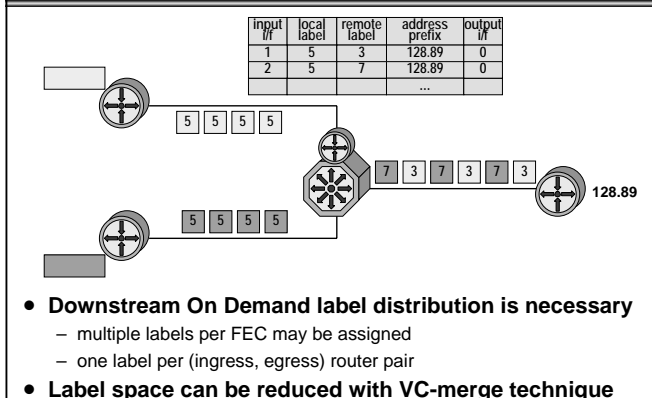

L14 - Multiprotocol Label Switching

VC Merge Technique

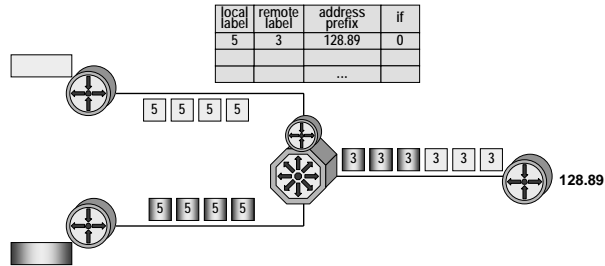

- **ATM switch avoids interleaving of frames**
 - VC Merge technique
 - looking for AAL5 trailers and storing corresponding cells of a frame until AAL5 trailer is seen

Agenda

- Review ATM
- IP over WAN Problems (Traditional Approach)
- MPLS Principles
- Label Distribution Methods
- RFC's

L14 - Multiprotocol Label Switching

MPLS Applications and MPLS Control Plane

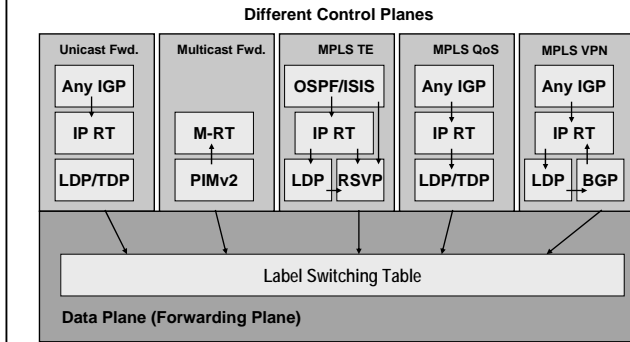

RFC References

1

- **RFC 3031**
 - Multiprotocol Label Switching Architecture
- **RFC 3032**
 - MPLS Label Stack Encoding
- **RFC 3036**
 - LDP Specification
- **RFC 3063**
 - MPLS Loop Prevention Mechanism
- **RFC 3270**
 - MPLS Support of Differentiated Services

L14 - Multiprotocol Label Switching

RFC References

2

- **RFC 3443**
 - Time To Live (TTL) Processing in MPLS
- **RFC 3469**
 - Framework for Multi-Protocol Label Switching (MPLS)-based Recovery
- **RFC 3478**
 - Graceful Restart Mechanism for Label Distribution Protocol
- **RFC 3479**
 - Fault Tolerance for the Label Distribution Protocol (LDP)